

MTX-416

PROGRAMMABLE 4x16
INTERCOM MATRIX

OWNERS MANUAL

AUDIO ELECTRONICS DESIGN



EQUIPOS EUROPEOS ELECTRÓNICOS, S.A.L

Avda. de la Industria, 50. 28760 TRES CANTOS-MADRID (SPAIN).



34-91-761 65 80



34-91-804 43 58



altair@altairaudio.com

www.altairaudio.com



1. INTRODUCTION.....	3
2. SWITCHES, CONTROLS, ADJUSTMENTS AND CONNECTORS	4
FRONT PANEL	4
REAR PANEL	5
3. WORKING PRECAUTIONS.....	6
4. INSTALLATION	6
UNPACKING.....	6
MOUNTING	6
CHANGING THE FUSE.....	6
CONNECTING TO THE MAINS.....	7
INTERCOM / AUDIO CHANNELS CONNECTION.....	7
INTERCOM / AUDIO LINES CONNECTION.....	8
SYSTEM EXPANSION	9
COMPUTER CONNECTION.....	13
5. OPERATION	13
DISPLAY.....	14
DIRECT MEMORY RECALL SWITCHES (M1-M5).....	14
MEMORY STORE SWITCH.....	15
MEMORY PREVIEW SWITCH	15
MEMORY CLEAR SWITCH	16
REVERSE MODE SWITCH	16
6. OPTIONS	16
SECURITY COVER (TP-1)	16
7. SPECIAL OPERATIONS.....	16
OPENING THE INTERCOM CHANNEL TERMINAL IMPEDANCE.....	17
POWER THE CHANNELS 3 AND 4 BY THE CHANNELS 1 AND 2	17
8. BLOCK DIAGRAM	18
9. APPLICATION EXAMPLE.....	19
10. TECHNICAL SPECIFICATIONS.....	20
11. WARRANTY	21



1. INTRODUCTION

Congratulations on your purchase of the **ALTAIR** intercom matrix **MTX-416**. There is a lot the characteristics that make of the **ALTAIR MTX-416** series one of the most highlighted in the audio professional market, some are enumerated here:

- The new Altair MTX-416 is a programmable Intercom Matrix allowing instant recall of up to 5 different presets. Each preset determines the allocation of up to 16 intercom lines into the 4 available intercom channels.
- The Matrix operates in vertical and exclusive mode, so any intercom equipment connected to line 1 for example can be addressed exclusively to one of the 4 channels.
- Power to the lines is taken from the 4 intercom channels and distributed to the selected lines.
- The design incorporates input and output link connectors for easy X and Y expansion of number of channels and/or lines. An 8 channels to 32 lines matrix system can be done with 4 units.
- The use of a Matrix in any medium to large size intercom system allows for daily instant reorganization of the full intercom functionality and the ability for easy reconfiguration by the system administrator.
- The unit can also be used as an 4 in to 16 out Audio matrix and by using the reverse mode, it can be operated as a 16 in to 4 out matrix-selector operating in horizontal exclusive mode.

Before beginning it is important to read this manual. This manual will help you to install and use your new intercom matrix. It is very important to read it carefully, mainly the paragraphs marked as NOTE, PRECAUTION and DANGER, for your security.

Save the original packing, you can re-use it to transport the unit. **NEVER SHIP THE ALTAIR MTX-416 WITHOUT ITS ORIGINAL PACKING.**



2. SWITCHES, CONTROLS, ADJUSTMENTS AND CONNECTORS

These are the switches, controls, adjustments and connectors that you can find in your ALTAIR matrix. The description and explanation of each one will be found in the corresponding section.

FRONT PANEL

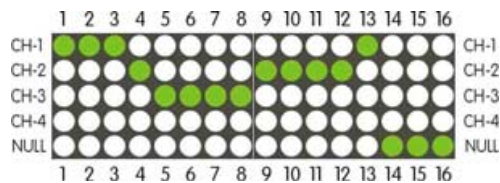
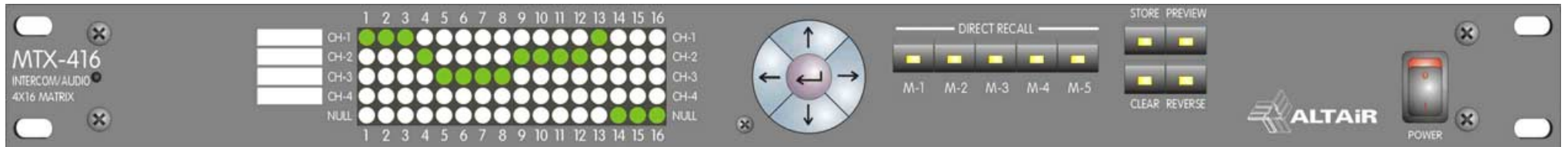

DISPLAY

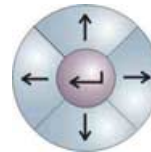

NAVIGATION SWITCHES:
UP, DOWN, LEFT, RIGHT, AND ENTER.



DIRECT RECALL SWITCHES (M1-M5).



MEMORY STORE SWITCH.



MEMORY PREVIEW SWITCH.



MEMORY CLEAR SWITCH.



REVERSE MODE SWITCH.



POWER SWITCH.



REAR PANEL

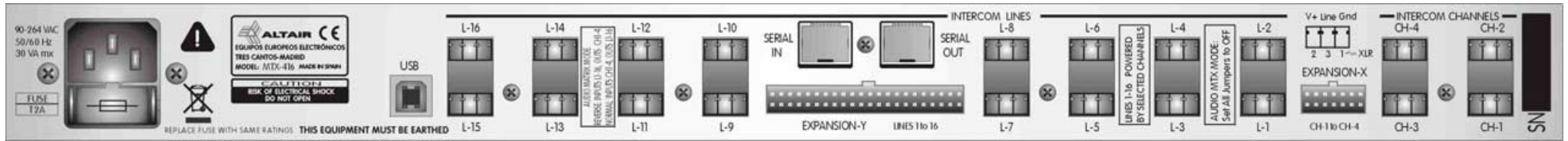

MAINS CONNECTOR AND FUSEHOLDER.



USB CONNECTOR FOR COMPUTER CONTROL.

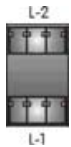

PHOENIX™ CONNECTORS TO CONNECT THE INTERCOM LINES (L1 – L16).



CONECTORES FCC-68 DE ENCADENAMIENTO DE UNIDADES.



IDC CONNECTOR FOR LINE EXPANSION IN LINKED UNITS.

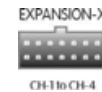

IDC CONNECTOR FOR CHANNEL EXPANSION IN LINKED UNITS.



PHOENIX™ CONNECTORS TO CONNECT THE INTERCOM CHANNELS (CH1 – CH4).

3. WORKING PRECAUTIONS

- The manufacturer is not responsible of any damage that can possibly happen to the unit outside the limits of the warranty or those produced by not taking care with the working precautions.
- Mains voltage must be between the limits of the admitted power supply (90-264 VAC, 50-60 Hz) and that the fuse must be the appropriate (2A slow blow type: T2A). Damage caused by connection to improper AC voltage is not covered by any warranty.
- **DANGER:** *Inside the unit there are high voltages, do not open it. The unit does not contain elements that could be repaired by the user. Whenever the unit is connected to the mains, it carries elements with high voltages. In order to disconnect the unit completely, you must disconnect it from the mains.*
- **CAUTION:** *Protect the unit from the rain and moisture. Ensure that no objects or liquids enter it. If liquid is spilled into the unit, disconnect it from the mains and consult a qualified service technician.*
- Do not place the unit close to heat sources.



4. INSTALLATION

UNPACKING

Before leaving the factory, each intercom matrix has been carefully inspected and tested. Unpack and inspect the unit for any damage that may have occurred during shipment. If any damage is found, does not connect the unit to the mains; notify the salesperson immediately; a qualified service technician should inspect the unit.

Save the original packing, you could use if you need to transport the unit. **NEVER SHIP THE INTERCOM MATRIX WITHOUT ITS ORIGINAL PACKING.**

MOUNTING

It is always recommended to mount the unit in rack, either for mobile or fixed installations, for protection, safety, aesthetics, etc.

The ALTAIR MTX-416 is designed for standard 19" rack mounting, and takes up 1u high rack space.

CHANGING THE FUSE

This unit incorporates an internal, worldwide voltage operation power supply, and it is prepared to work from 90 to 264 VAC, 50-60Hz.

- 1 Make sure that the unit is disconnected from the mains.
- 2 In the unit rear panel are placed the mains connector, the mains selector and the fuse holder. The box bellows this mains connector is called fuse holder. Take out the fuse holder.

- 3 After extracting the fuse holder, the fuse will appear, take out it and change for the new one.
- 4 Insert the fuse holder into the mains connector again.
- 5 Make sure that the fuse is the right one: 2A slow blow type - **T2AZ**



CAUTION: Always make sure after changing the fuse, that it is the right one.

CONNECTING TO THE MAINS

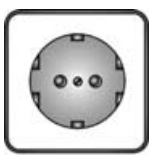

The connection of the intercom matrix power supply to the mains takes place by a standard cord included in the box.



- 1 Make sure that the unit power switch is at 0 position (turned off).
- 2 Insert the female I.E.C. connector of the tripolar cable into the unit power supply male connector, placed at the rear panel.
- 3 Insert the male connector of the tripolar cable into the mains plug.
- 4 Turn on the unit power switch. In that moment, all the leds of the unit will light slightly, indicating that the unit is turned on



CAUTION: Make sure that the mains voltage is the correct as well as their fuse is the right one.

INTERCOM / AUDIO CHANNELS CONNECTION

If we are going to use ALTAIR MTX-416 like intercom matrix, we will connect the intercom channels CH1-CH4 to a unit with active intercom channels (ALTAIR EF-200, ALTAIR WBS-200, or any compatible CLEAR COM™). The signal distribution in the PHOENIX™ connector is the following one:

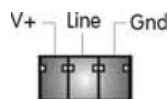

The cable and the connection to a XLR connector are described in the following graph:

ALTAIR MTX-416
PHOENIX™ CONNECTOR
CH1-CH4



INTERCOM CHANNEL
WITH MALE XLR.



ALTAIR MTX-416
PHOENIX™ CONNECTOR
CH1-CH4

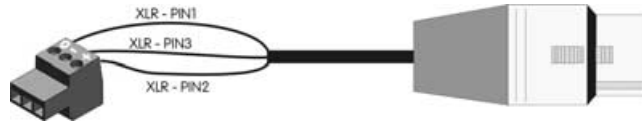

INTERCOM CHANNEL
WITH FEMALE XLR.

If we used the ALTAIR MTX-416 like audio matrix, we will connect the audio channels CH1-CH4 to four audio inputs (for normal mode: 4 IN - 16 OUT) or four audio outputs for the inverted mode (REVERSE- 16 IN - 4 OUT). The signal distribution in the PHOENIX™ connector is the following one:

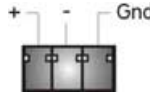

The cable and the connection to a XLR connector are described in the following graph:

ALTAIR MTX-416
PHOENIX™ CONNECTOR
CH1-CH4



AUDIO INPUT,
XLR MALE, FOR
NORMAL MODE
4 IN – 16 OUT.

ALTAIR MTX-416
PHOENIX™ CONNECTOR
CH1-CH4



AUDIO OUPUT
XLR FEMALE, FOR
REVERSE MODE
16 IN – 4 OUT.

INTERCOM / AUDIO LINES CONNECTION

If the ALTAIR MTX-416 unit is used like intercom matrix, we will connect the intercom lines L1-L16 to a unit with intercom passive channels (ALTAIR ES-200, ALTAIR EM-201, or any compatible CLEAR COM™). The signal distribution in the PHOENIX™ connector is the following one:

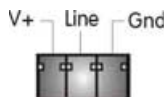

The cable and the connection to a XLR connector are described in the following graph:

ALTAIR MTX-416
CONECTOR PHOENIX™
L1 - L16



INTERCOM LINE
WITH XLR MALE.

ALTAIR MTX-416
PHOENIX™ CONNECTOR
L1 – L16



INTERCOM LINE
WITH XLR FEMALE.

If we used the ALTAIR MTX-416 like audio matrix, we will connect the audio lines L1-L16 to sixteen audio outputs (for normal mode: 4 IN - 16 OUT) or sixteen audio outputs for the inverted mode (REVERSE- 16 IN - 4 OUT). The signal distribution in the PHOENIX™ connector is the following one:

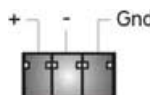

The cable and the connection to a XLR connector are described in the following graph:

ALTAIR MTX-416
PHOENIX™ CONNECTOR
CH1-CH4

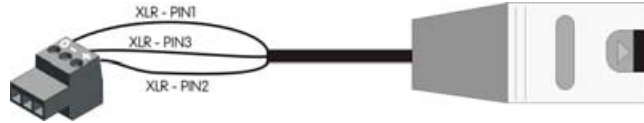

AUDIO INPUT,
XLR MALE, FOR
NORMAL MODE
4 IN – 16 OUT.

ALTAIR MTX-416
PHOENIX™ CONNECTOR
CH1-CH4



AUDIO OUTPUT
XLR FEMALE, FOR
REVERSE MODE
16 IN – 4 OUT.

SYSTEM EXPANSION

The connection of up to four units ALTAIR MTX-416 allows to make matrix with up to 4 channels, 64 lines, increasing the line number, or up to 16 channels and 16 lines, increasing the number of channels, with all the intermediate situations.

Altogether we can link four units, if we want to increase the line number, we will link the units by means of the EXPANSION-Y connector and if we want to increase the number of channels, we will link the units by means of the EXPANSION-X connector.



If we want that the memory change works simultaneously in all the units, or to control all the units from a computer via USB, will connect the SERIAL OUT output of the first unit (by means of a 8 pin RJ45 cable without inverting) to SERIAL IN input of the second, SERIAL OUT output of the second to SERIAL IN input of third... and SERIAL OUT output of the last one to SERIAL IN input of first. In the following diagrams, are show the different possibilities:

8x16 MATRIX:

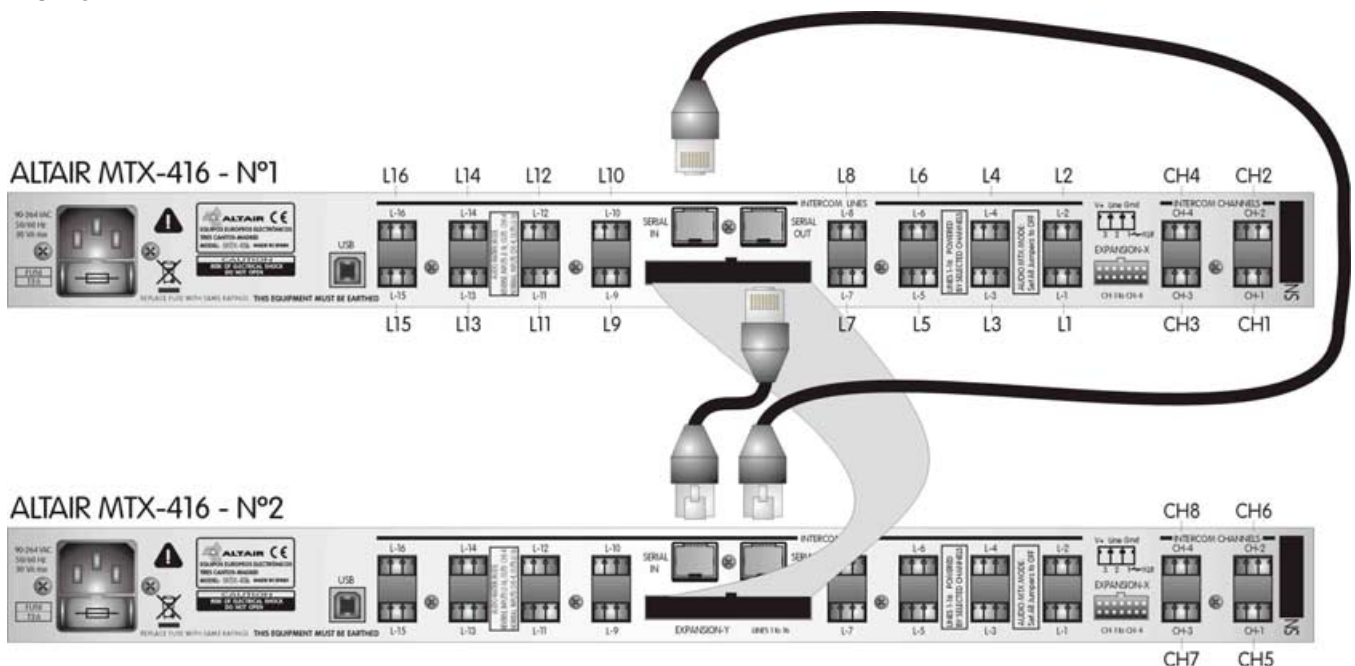



12x16 MATRIX:

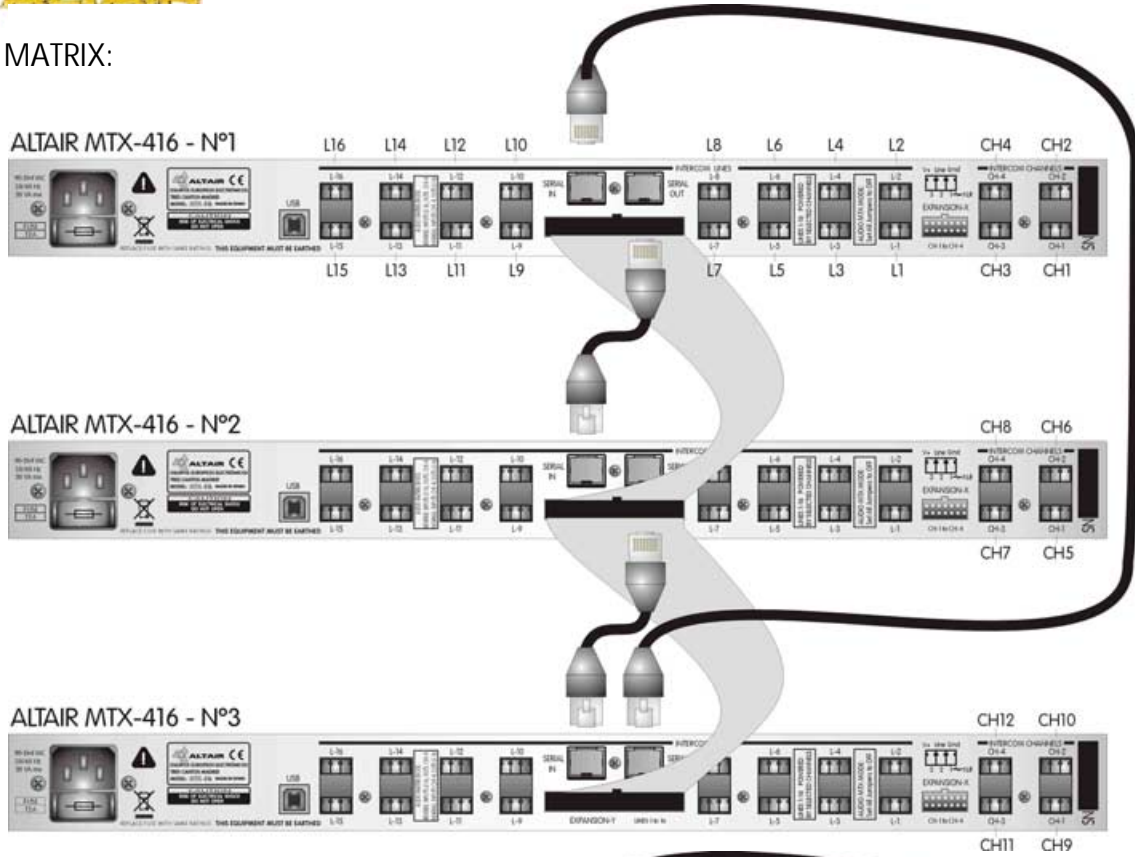

16x16 MATRIX:

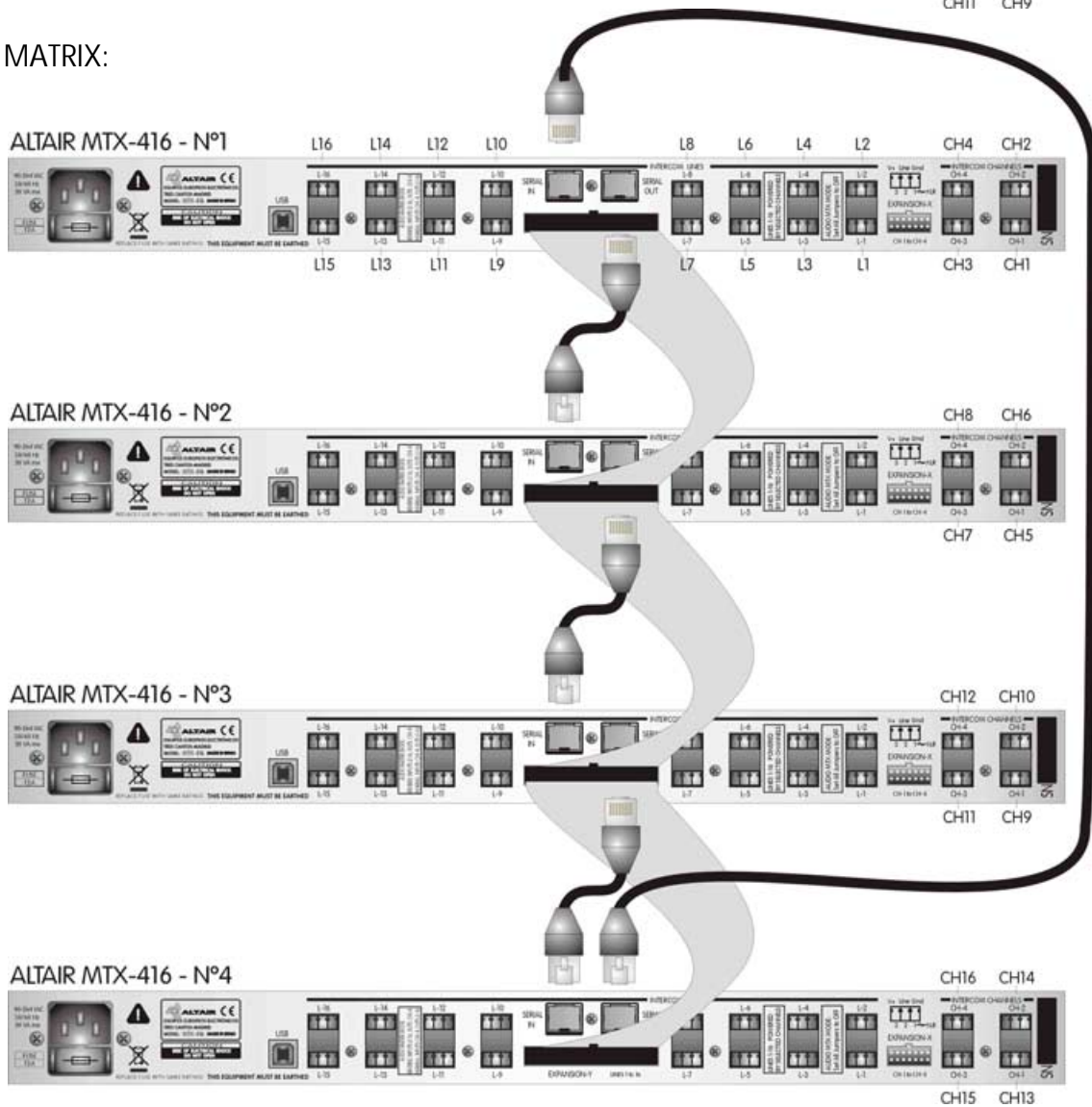

4x32 MATRIX:

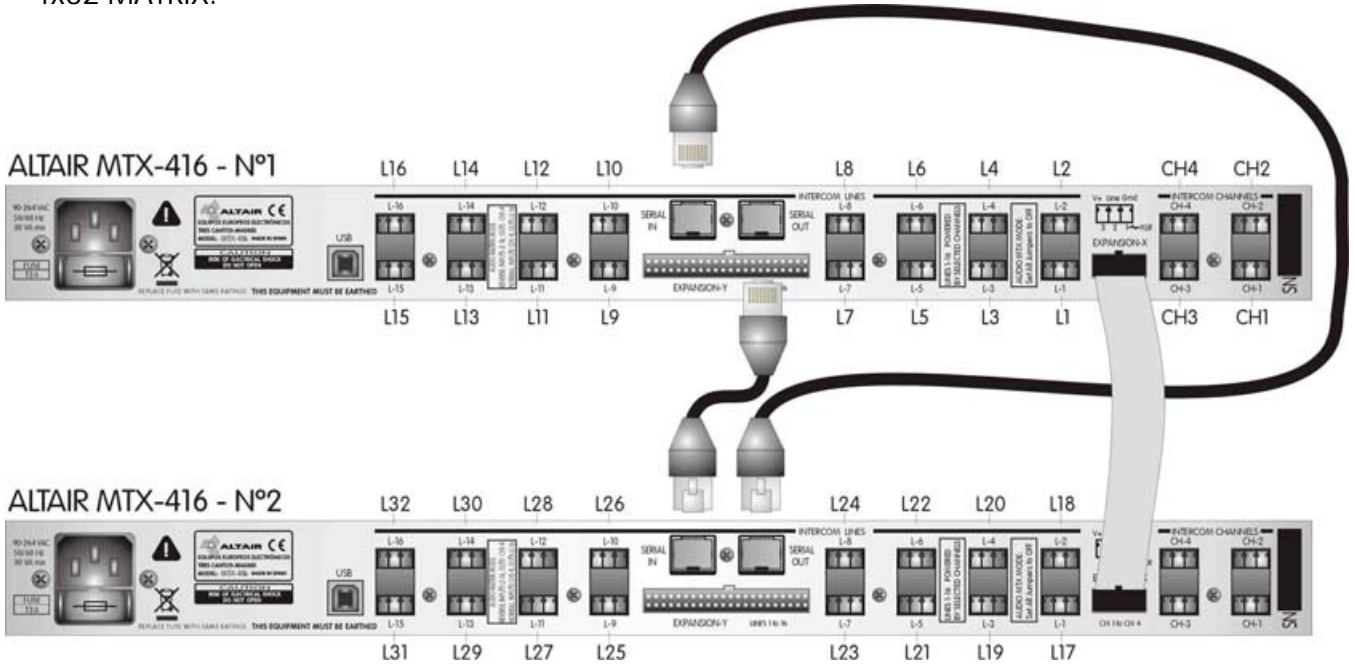

4x48 MATRIX:

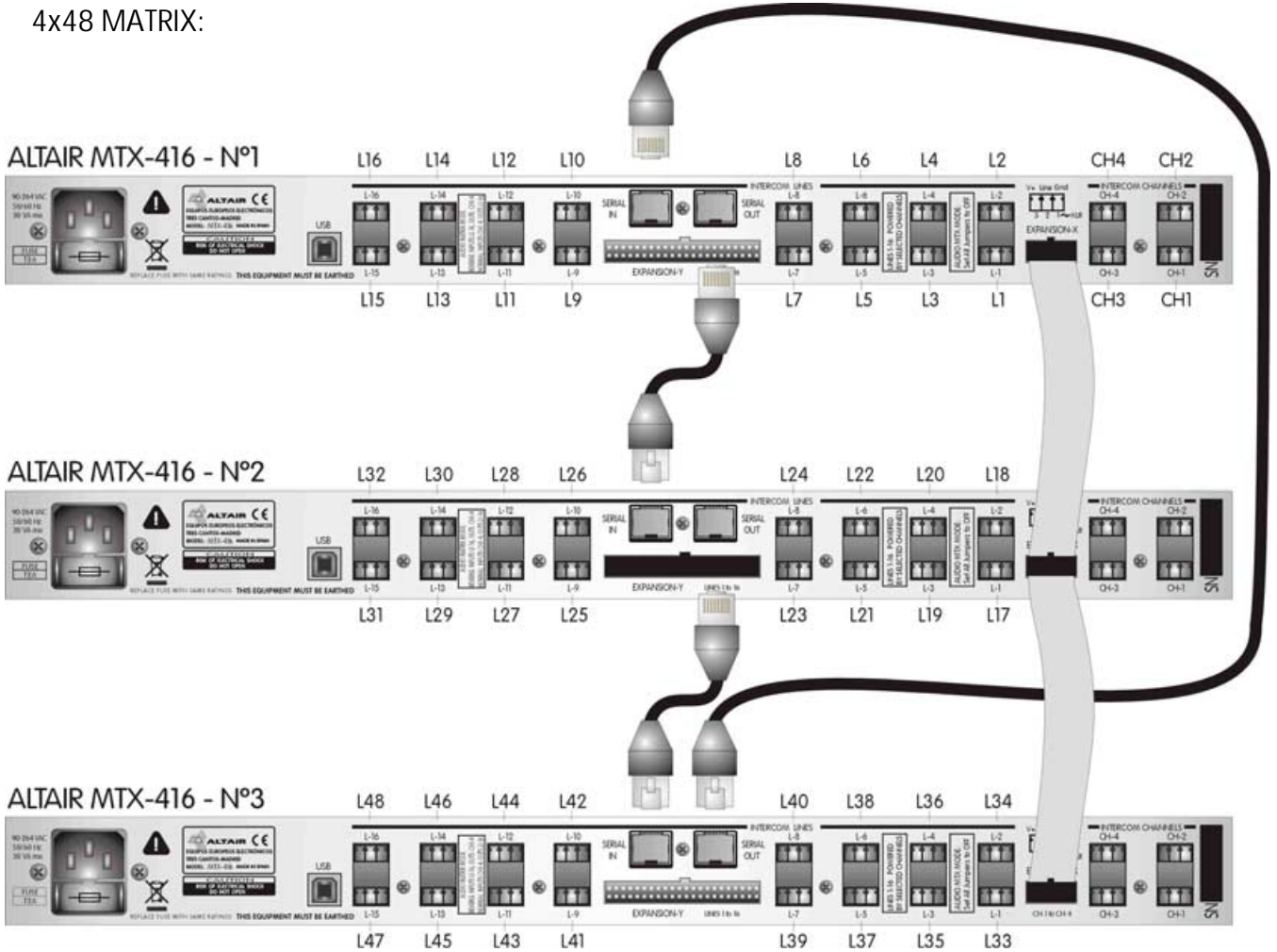



4x64 MATRIX:

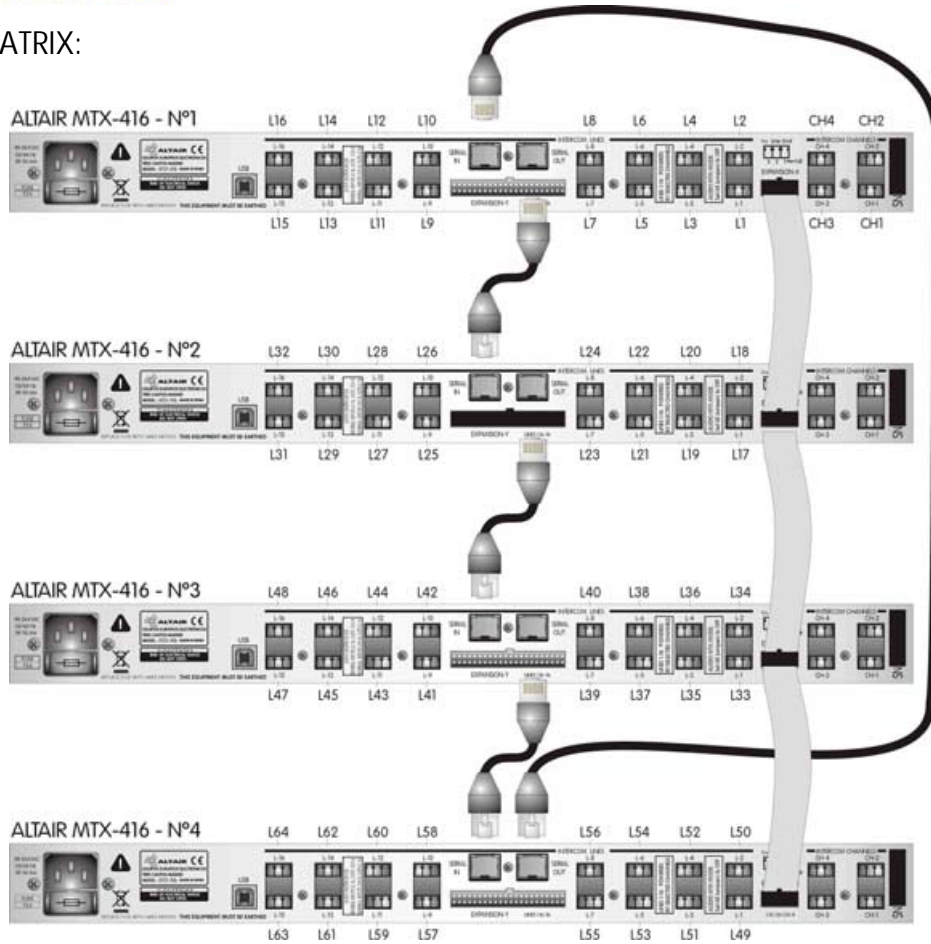

8x32 MATRIX:

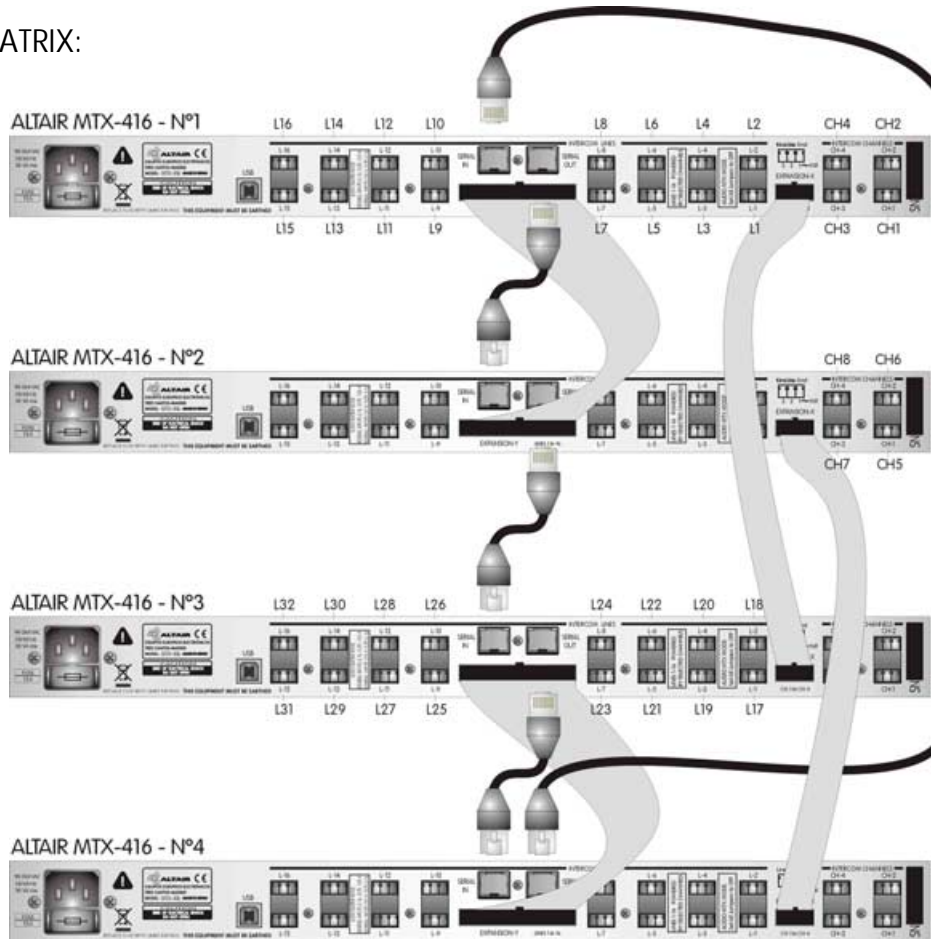



COMPUTER CONNECTION

The connection to a computer is made by means of an USB MALE A / MALE B cable, which allows to control all the functions of up to four ALTAIR MTX-416 units. The cable is connected to the computer and anyone of the four units. With the control software, the USB driver for the computer is enclosed.



5. OPERATION

The new Altair MTX-416 is a programmable Intercom Matrix allowing instant recall of up to 5 different presets. Each preset determines the allocation of up to 16 intercom lines into the 4 available intercom channels.

The Matrix operates in vertical and exclusive mode, so any intercom equipment connected to line 1 for example can be addressed exclusively to one of the 4 channels.

Power to the lines is taken from the 4 intercom channels and distributed to the selected lines.

The design incorporates input and output link connectors for easy X and Y expansion of number of channels and/or lines. An 8 channels to 32 lines matrix system can be done with 4 units.

The use of a Matrix in any medium to large size intercom system allows for daily instant reorganization of the full intercom functionality and the ability for easy reconfiguration by the system administrator.

The unit can also be used as a 4 in to 16 out Audio matrix and by using the reverse mode, it can be operated as a 16 in to 4 out matrix-selector operating in horizontal exclusive mode.



DISPLAY

Display configured matrix), it will the channel connected to will be lighting a LED by each channel, indicating to witch line is connected this channel, or turned off, if this channel is not connected to any line.

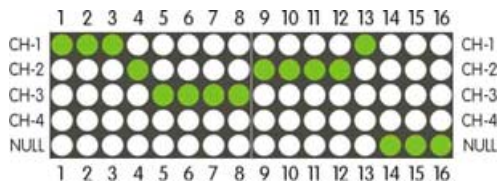

allows us to know as ALTAIR MTX-416 is with a simple browse. In normal mode (4x16 indicate to us with a LED lighting in each line, to which is connected this line (NULL if it is not any channel). In reverse mode (16x4 matrix),

Also display will indicate to us the different action types that the unit hopes of the user, guiding the user at every moment to the keys that must press.

NAVIGATION SWITCHES: UP, DOWN, LEFT, RIGHT AND ENTER:

The navigation switches allow to move by the different lines and channels of the ALTAIR MTX-416 unit. Also ENTER switch, allows to confirm diverse functions, which will be explained more ahead.

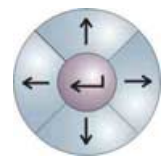

The first switch pulsation (UP, DOWN, LEFT, RIGHT or ENTER), does that the unit enter in edition mode. If it is the first time that enters in edition mode since the unit is turned on, it will be positioned in the line 1, whose LED will begin to blink (in REVERSE mode, will be positioned in channel 1, whose LED will begin to blink), if it has entered in edition mode previously, will be positioned in the last line to which access has been had (in REVERSE mode, will position in the last channel to which access has been had)

In edition mode, we have a cursor (LED blinking), with which we can be moved with the navigation switches, selecting each line to that channel we want to connect it (in REVERSE mode, we will select each channel to that line we want to connect it).

If we waited for a time without doing anything, the edition mode will be reset, and the LED will let blink. If we pressed a switch that is not of navigation, the edition mode will be reset and the LED will let blink. In order to change the line configuration (or the channel configuration in REVERSE mode), we must validate it with the ENTER switch, that is to say, we move with the switches UP, DOWN, LEFT and RIGHT and validate the configuration with the ENTER switch.

In edition mode, if we pressed the UP switch, on the selected line, the channel number will decrease (it is looped, once it arrive to CH1 it pass to NULL), in REVERSE mode, acts in the same mode, decreasing the channel number, but does not exist the NULL position and it will be positioned on the line to which the selected channel is connected.

When the DOWN switch is pressed, on the selected line, will increase the channel number (it is looped, once it arrive to NULL it pass to CH1), in REVERSE mode, acts in the same mode, increasing the channel number, but does not exist the NULL position and it will be positioned on the line to which the selected channel is connected.

In edition mode, if we pressed the RIGHT switch, it will increase the line number (it is looped, once it arrive to line 16 it pass to line 1), positioning itself on the channel to which this line is connected. In REVERSE mode acts in the same mode, increasing the line number (it is looped, once it arrive to line 16 it pass to line 1).

DIRECT MEMORY RECALL SWITCHES (M1-M5)

The ALTAIR MTX-416 unit has five memories for the normal mode and five memories for the REVERSE mode, plus a working memory (one for the NORMAL mode and other the REVERSE mode), that is the one that is active in the unit.



One of the five LED associated to the switches, remains lighting, indicating the memory in which it is located the unit. If the working memory and the stored memory are the same, the LED will remain without blinking, and if the working memory and the stored memory are different, the LED will be blinking.

By means of these five keys it is possible to be acceded of direct mode to the five stored memories, always considering that when recovering a stored memory, the working memory will be lost.

Mediante estas cinco teclas se puede acceder de manera directa a las cinco memorias almacenadas, siempre teniendo en cuenta que al recobrar una memoria guardada, la memoria de trabajo se perderá.

It exists a memories bank for the NORMAL mode and other for the REVERSE mode, reason why five memories for each mode can be recorded.

When acceding to a determined memory, if the system were linked with other MTX-416 units, they will change all the connected units, to the memory number to which we have acceded.

MEMORY STORE SWITCH

The store switch allows us to record the working memory on anyone of the five memories (M1-M5) available in the system.

When pressing the STORE switch, display will indicate M1-5 blinking, the five leds of the direct memory recall switches will begin to blink, as well as the LED corresponding to the STORE switch, being indicated that we are in recording mode.



The unit reset the recording mode if we do nothing or press a switch other than STORE, M1 – M5, in a few seconds.

If we pressed one of the direct memory recall switches (M1-M5), the working memory will be recorded in the memory number corresponding to the pressed key.

When the memory is recorded, the unit change to the memory number on which we have recorded the working memory, reason why if the system were linked with other MTX-416 units, all the connected units will change to the memory number on which the working memory has been recorded.

MEMORY PREVIEW SWITCH

With this PREVIEW switch we can see the memories recorded directly in display

When pressing the PREVIEW switch, display will indicate M1-5 blinking, the five leds of the direct memory recall switches will begin to blink, as well as the LED corresponding to the PREVIEW switch, being indicated that we are in preview mode.

The unit reset the preview mode if we do nothing or press a switch other than STORE, M1 – M5, in a few seconds.

If we pressed one of the direct memory recall switches (M1-M5), the corresponding memory will appear in the display blinking, as well as it will continue blinking the PREVIEW switch. Passed a few seconds, the system will return to normal mode.



MEMORY CLEAR SWITCH

By means of the memory CLEAR switch, we can reset the working memory, so that in normal mode, all the lines are disconnected of the channels, and in reverse mode all the channels are disconnected of the lines.



When pressing the memory CLEAR switch, the display will indicate YES? blinking, as well as the LED corresponding to the CLEAR switch, indicating that we are in memory clear mode.

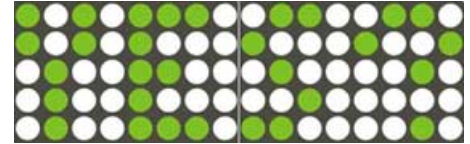

The unit reset the memory clear mode if we do nothing or press a switch other than ENTER, in a few seconds.

If we pressed the ENTER switch, the working memory will erase, disconnecting all the lines of the channels in normal mode, or all the channels of the lines in reverse mode.

REVERSE MODE SWITCH

When pressing this REVERSE mode switch, we can change the working mode, 4 IN x 16 OUT in NORMAL mode or 16 IN x 4 OUT in REVERSE mode.



In format 4 IN x 16 OUT, each one of the sixteen lines (OUT) can be connected to one of the four channels (IN).

In format 16 IN x 4 OUT, each one of the four channels (OUT) can be connected to one of the sixteen lines (IN).



When pressing the REVERSE switch, the display will indicate YES? blinking, as well as the LED corresponding to the REVERSE switch, indicating that we are in reverse mode change.

The unit reset the reverse mode change if we do nothing or press a switch other than ENTER, in a few seconds.

If we pressed the ENTER switch, we will change the mode: If we were in NORMAL mode we will turn to REVERSE mode and vice versa.

In REVERSE mode, the REVERSE LED will remain turned on, indicating to us that the unit is configured in REVERSE mode.

6. OPTIONS

In this section we will explain the different available options for the intercom matrix ALTAIR MTX-416.

SECURITY COVER (TP-1)

In some installation, it may be necessary to tamper proof the front panel controls avoiding unwanted or accidental manipulations. For this purpose, it is available as an option, a transparent plastic security cover. The installation is very easy, only with two provided screws.

7. SPECIAL OPERATIONS

In order to set-up some of the intercom matrix possibilities, the unit must be opened removing the eight screws of the unit top cover

NOTE: This type of operations takes place with the unit is opened; the best thing should be to carry it out by a qualified technician.



DANGER: Before opening the unit, disconnect it from the mains. It is important to indicate that although the unit is switched off (with the power switch in 0 position), if it keeps being connected to the mains there are different parts of the unit that are subjected to high voltage.

CAUTION: Protect the intercom matrix from the rain and moisture, mostly if it is open. If liquid is spilled into the unit, disconnect it from the mains and consult a qualified service technician.

OPENING THE INTERCOM CHANNEL TERMINAL IMPEDANCE

The intercom channels should have a terminal impedance to make the different units connected to them work correctly, however only one can connect a terminal impedance for channel because if they are connected two in parallel, the impedance would diminish in a half; for this and in order to connect other units with a terminal impedance, it is possible to open the terminal impedance placed in each of the channels of the unit (NOTE: Keep in mind that with all the units of the ALTAIR E-200 intercom system of ALTAIR it is necessary to open the terminal impedance).

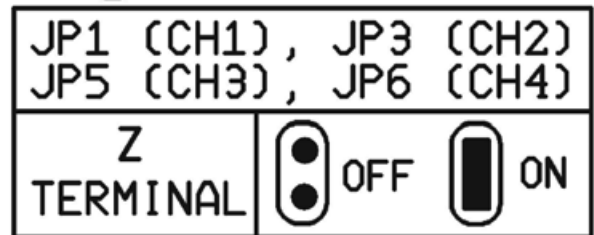

In order to open the intercom channel terminal impedance the MTX-416 provide some jumpers (JP1 for the channel 1, JP3 for the channel 2, JP5 for the channel 3 and JP6 for the channel 4) placed at the left part of the main PCB, near the rear panel looking at the unit from the front panel. With the jumper placed, the terminal impedance will be connected and with the jumper removed, it will be open.

CAUTION: Never leave the intercom channel without terminal impedance, because a bad operation of the units connected to the line would take place.

NOTE: The factory setting is with the terminal impedance jumper disconnected.

POWER THE CHANNELS 3 AND 4 BY THE CHANNELS 1 AND 2

Intercom channels 1 and 2 can power intercom channels 3 and 4, by means of two jumpers located inside the unit. The power is take out directly of the intercom line connected to channel 1 and/or 3, reason why must refer to the manual of the units connected to the intercom channels 1 and 2 for the specifications of power and current.

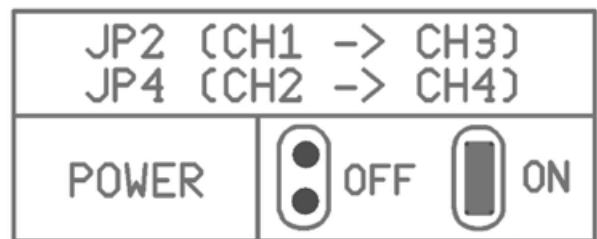

With the jumper JP2 placed, the intercom channel CH3 will be powered by means of the intercom channel CH1, with the jumper removed, the intercom channel of CH3 will not be powered through intercom channel CH1.

With the jumper JP4 placed, the intercom channel CH4 will be powered by means of the intercom channel CH2, with the jumper removed, the intercom channel of CH4 will not be powered through intercom channel CH2.

The jumpers are placed at the left part of the main PCB, near the rear panel looking at the unit from the front panel.

NOTE: The factory setting is with the power jumpers disconnected.



8. BLOCK DIAGRAM

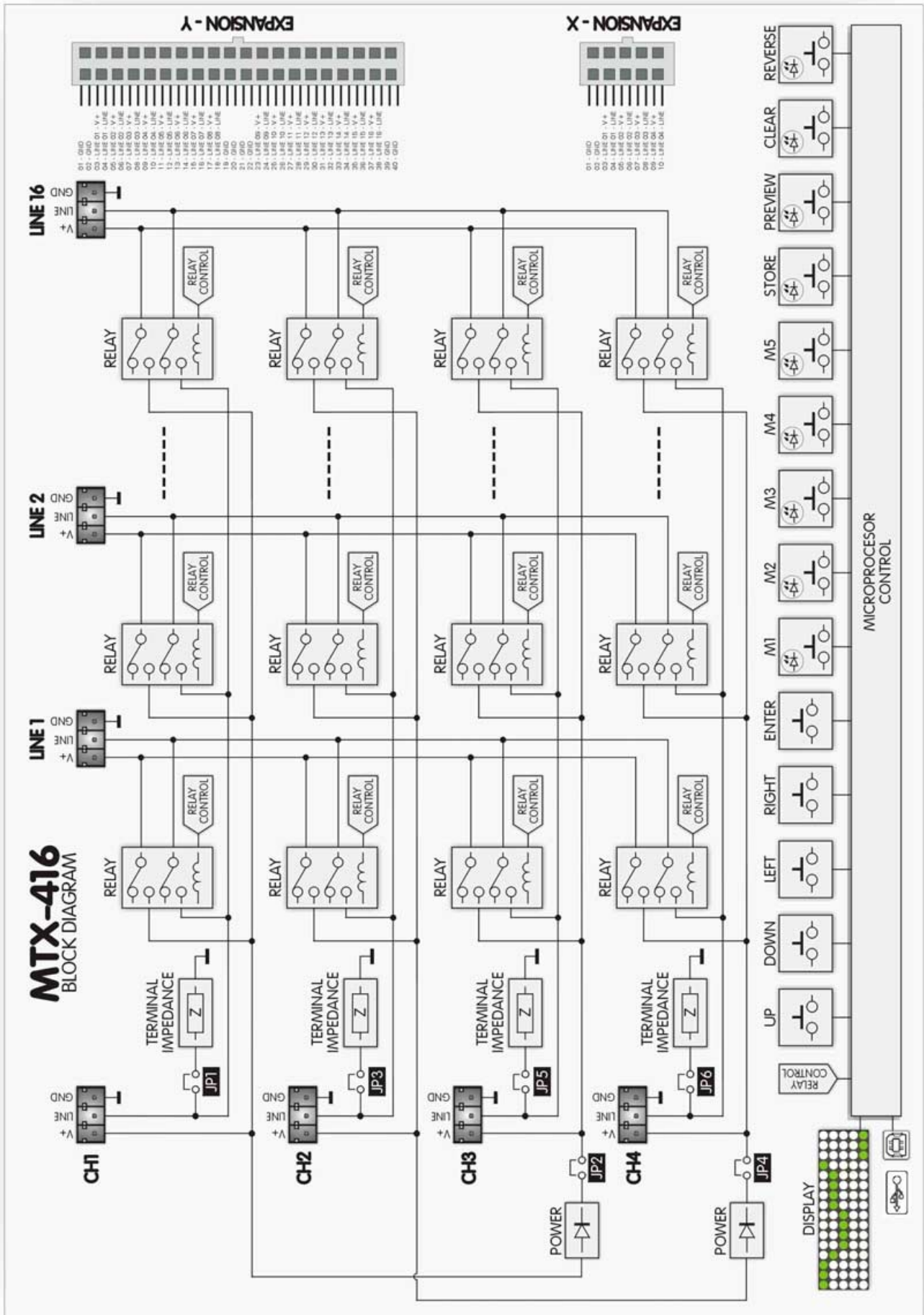

9. APPLICATION EXAMPLE

In the following schematic drawing an application example is represented, summarize of most of the situations in which it can be.

It is a system with four intercom lines, formed by two ALTAIR EF-200 units.

The different units (ES-200, EM-201, 4W2-200, WBS-200), are connected to the intercom lines by means of the ALTAIR MTX-416 matrix, reason why we have an open and flexible system, being able to control remotely, by means of matrix MTX-416 the configuration of the intercom lines in real time.

If we added a computer control, a remote user, could control the matrix configuration, that is to say, the intercom lines, even being possible a configuration change due to an external control signal at the system, as can be the activation of a fire alarm.

It is then tried to make flexible the intercom lines configuration, so that the configuration in real time can be changed.

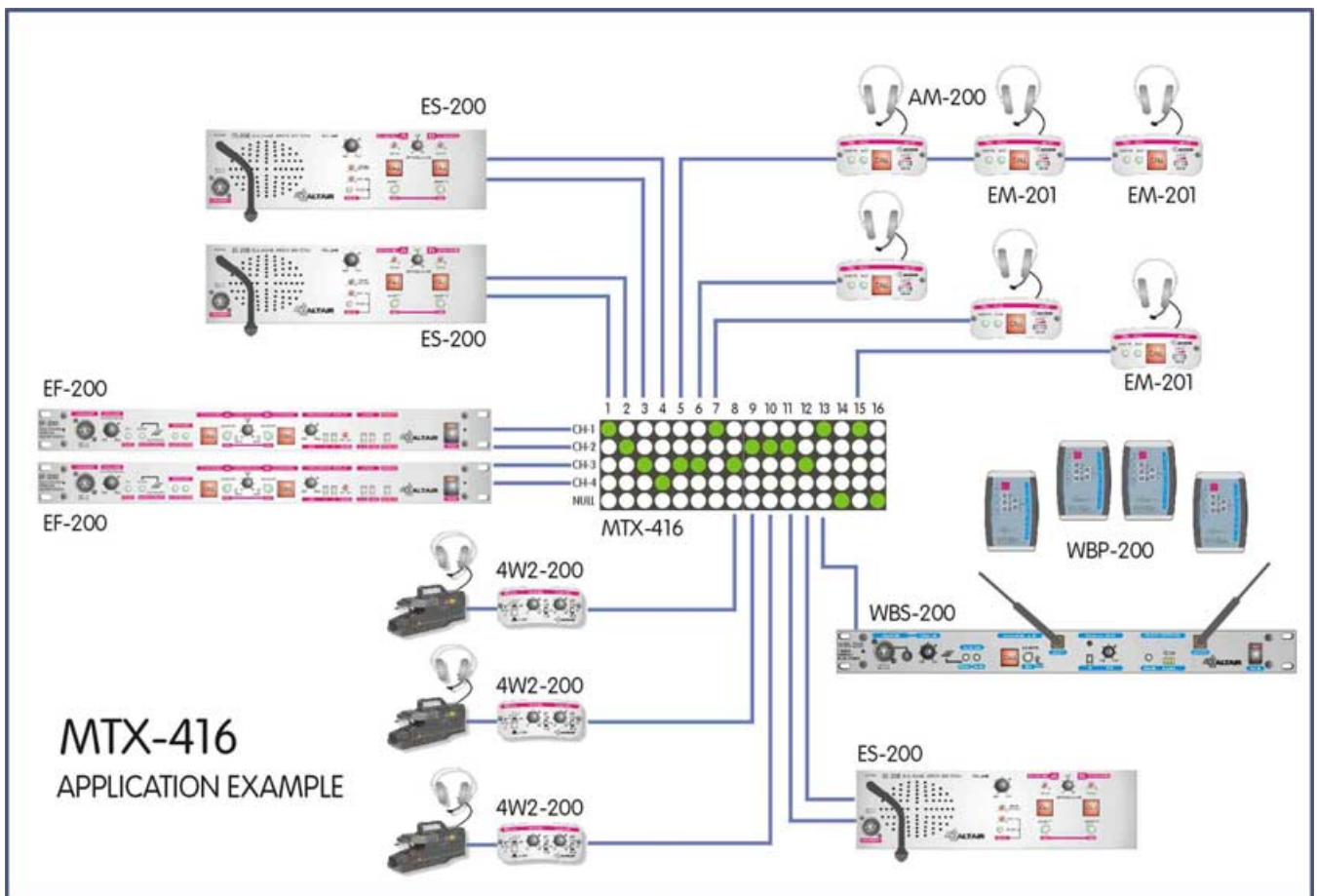



10. TECHNICAL SPECIFICATIONS

INTERCOM LINE	IMPEDANCE:	<ul style="list-style-type: none"> • 220 Ω AC. • 4700 Ω DC.
	NOMINAL/MAXIMUM LEVEL:	<ul style="list-style-type: none"> • -10 dBu / +3 dBu.
	FREQUENCY RESPONSE:	<ul style="list-style-type: none"> • 100 Hz – 10 KHz (-3 dB).
SYSTEM SPECIFICATIONS	MAXIMUM CABLE LENGTH:	<ul style="list-style-type: none"> • 500-2.000 mts. Depends on installation.
	RECOMMENDED WIRE TYPE:	<ul style="list-style-type: none"> • Shielded mic cable 2 x 0,30 mm².
RELAYS	CONNECTIONS:	<ul style="list-style-type: none"> • 1 NO+1 NC circuit /JACK ¼".
	CONTACTS:	<ul style="list-style-type: none"> • 0,5 Amp @ 125 VAC/ 1 Amp @ 30 VDC.
POWER SUPPLY	MAINS VOLTAGE:	<ul style="list-style-type: none"> • 90-264 VAC/ 50-60 Hz.
	POWER SUPPLY:	<ul style="list-style-type: none"> • 12 VDC nominal/ 1,8 Amperes.
	PROTECTIONS:	<ul style="list-style-type: none"> • Short circuit on the line, overheat.
	POWER REQUIREMENTS:	<ul style="list-style-type: none"> • 50 VA maximum.
ACCESSORIES	PLASTIC SECURITY COVER:	<ul style="list-style-type: none"> • REF: TP-1.
DIMENSIONS		<ul style="list-style-type: none"> • 1U x 19"x210 MM.
WEIGHT		<ul style="list-style-type: none"> • 3Kg. Net.

NOTE: Technical specifications are subject to variation without previous notice.



11. WARRANTY

This unit is warranted by Equipos Europeos Electrónicos to the original user, against flaws in the manufacturing and in the materials, for a period of one year, starting from the date of sale.

Flaws due to wrong use of the unit, internal modifications or accidents, are not covered by this warranty.

There is no other warranty expressed or implicit.

Any faulty unit must be sent to the dealer or the manufacturer. The serial number of the unit must be included for any request to the technical service.

Equipos Europeos Electrónicos reserves the right to modify the prices or the technical specifications without further notice.

SERIAL NUMBER

AUDIO ELECTRONICS DESIGN



EQUIPOS EUROPEOS ELECTRÓNICOS, S.A.L

Avda. de la Industria, 50. 28760 TRES CANTOS-MADRID (SPAIN).



34-91-761 65 80



34-91-804 43 58



altair@altairaudio.com

www.altairaudio.com

European Union Waste Electronics Information Unión Europea Información sobre residuos electrónicos

Waste from Electrical and Electronic Equipment (WEEE) directive

The WEEE logo signifies specific recycling programs and procedures for electronic products in countries of the European Union. We encourage the recycling of our products. If you have further questions about recycling, contact your local sales office.

Directiva sobre Residuos de Aparatos Eléctricos y Electrónicos (RAEE)

El logotipo de la Directiva RAEE se refiere a los programas y procedimientos específicos de reciclaje para aparatos electrónicos de países de la Unión Europea. Recomendamos el reciclaje de nuestros productos. Si tiene alguna consulta, póngase en contacto con su Distribuidor.



Information based on European Union WEEE Directive 2002/96/EC

Información basada en la Directiva de la unión europea RAEE 2002/96/EC y el Real Decreto 208/2005

AUDIO ELECTRONICS DESIGN



EQUIPOS EUROPEOS ELECTRÓNICOS, S.A.L

Avda. de la Industria, 50. 28760 TRES CANTOS-MADRID (SPAIN).



34-91-761 65 80



34-91-804 43 58



altair@altairaudio.com

www.altairaudio.com