

HD PTZ Color Video Cameras

User Manual V1.0

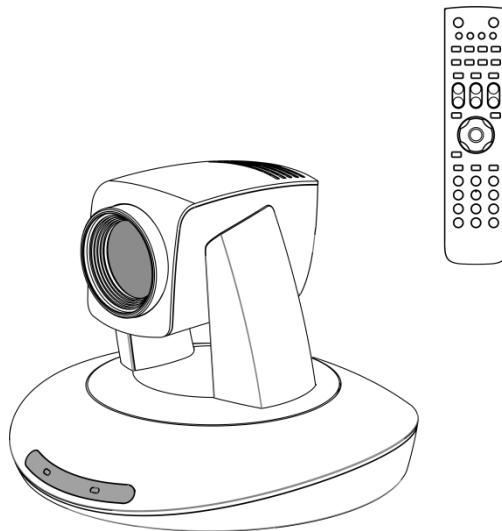

SAFETY NOTICE-IMPORTANT

The following important notes must be followed carefully to run the camera and respective accessories in total safety. The camera and relative accessories are called video system in this section.

- Before installing the camera, please read this manual carefully. Please follow installation instructions indicated in this manual during installation. Please keep this manual for future use.
- The installation should be performed by qualified service personnel or system installers in accordance with all local rules.
- Before powering on the camera, please check the power voltage carefully. Make sure that you are using the correct power source.
- Please put the power cable, video cable and control cable in safe place.
- Do not operate the camera beyond the specified temperature and humidity. Working temperature range of the camera is between 0°C and +40°C. The ambient humidity range is less than 95 % .
- During transporting, avoid violent shake or force to the camera.
- To prevent electric shock, do not remove screws or housing of the camera. There are no self-serviceable parts inside. Refer to qualified service personnel for servicing.
- Video cable and RS485 cable should be kept far away from other cables. Shielded and independent wiring is necessary for video and control cables.
- Never aim the lens of the camera at the sun or other extremely bright objects. Otherwise, it may cause damage.
- When cleaning the camera, please use soft cloth. If the camera is very dirty, wipe it off gently with a soft cloth moistened with a weak solution of water and a neutral kitchen detergent. Wring all liquid from the cloth before wiping the camera, then wipe off all remaining dirt with a soft, dry cloth. Use lens cleaning paper to clean the lens.

- Do not move the camera head manually. In doing so would result in malfunction of the camera. Do not hold the camera head when carrying the video camera.
- This camera is for indoor use only. It is not designed for outdoor use.
- Make sure the camera is not directly exposed to rain and water.
- Make sure the camera is far away from area where radiation, X-rays, strong electric waves, or magnetism is generated.

CONTENTS

ABOUT THE PRODUCT	1
FEATURES	1
LIST OF PARTS & ACCESSORIES	1
MAIN PARTS & INTERFACES	2
DIP SWITCHES SETTINGS	3
REMOTE CONTROLLER	5
CONNECTIONS	7
INSTALLATION	8
DESKTOP MOUNT INSTALLATION	8
WALL MOUNT INSTALLATION	8
CEILING MOUNT INSTALLATION	9
MENU SETTINGS	10
MENU CONFIGURATION	10
MENU EXPLANATION	14
VIDEO	15
EXPOSURE	15
WHITE BALANCE	16
PAN/TILT/ZOOM	17
SYSTEM	17
STATUS	18
RESTORE DEFAULTS	18
ANNEX 1 TECHNICAL SPECIFICATIONS	19
ANNEX 2 SIZE AND DIMENSION	20
ANNEX 3 SW1 DEFINITION	21
TROUBLESHOOTING	23

ABOUT THE PRODUCT

Features

- 1/2.8 inch Exmor CMOS sensor, 2.14 megapixel;
- Supports full resolution up to 1080p60 and SD video formats;
- Simultaneous outputs of HD and SD videos;
- HD video interfaces: 3G-SDI, DVI-I;
- OSD menu;
- 20x optical zoom, 12x digital zoom/30x optical zoom, 12x digital zoom;
- Precise driving system with high reliability and precision;
- Support VISCA , Daisy chain and Pelco protocols;
- With IR remote controller;
- Smart AE technology to effectively avoid the interference of complicated lights from projectors ,monitors etc;
- Desktop/Ceiling/ Wall mount optional.

List Of Parts & Accessories

When you open the box, check all accessories according to the packing list.

Camera (1)



Power Adapter (1)

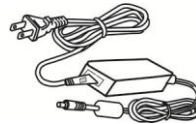

Remote Controller (1)

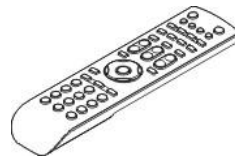

Cable Package (1)



Main Parts & Interfaces

Camera

Front View

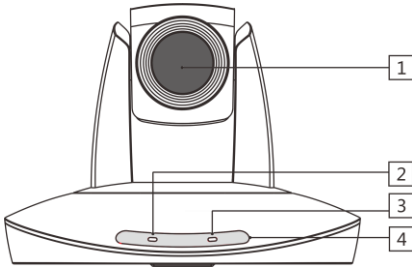

- 1 Camera Module
- 2 Communication Indicator
- 3 Power Indicator
- 4 Remote Controller Indicator

Rear View

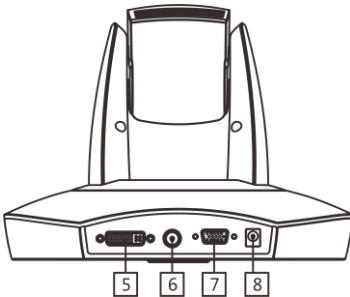

- 5 DVI-I interface
- 6 3G-SDI interface

- 7 Composite interfaces (CVBS output, RS-485/RS-422, RS-232 in and RS-232 out)
- 8 DC12V power input

Bottom View

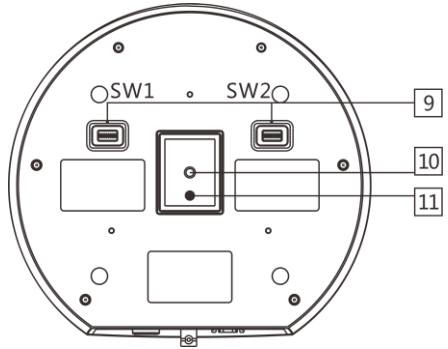

- 9 DIP Switch
 - Set camera address, protocol, baud rate, video format and mounting type.
- 10 Mounting Hole
 - 1/4"inch screw thread for fixing camera.
- 11 Locating Hole
 - To define installation direction of camera.

DIP Switches Settings

Before operating the camera, set the camera address, DVI-I output signal format and video format etc through DIP switches. The camera has two DIP switches: SW1 and SW2 as below:



Note

SW1 is used to set address, video output and mounting type, SW2 is used to set protocol, baud rate and video format.

Default Settings	
Address	1
Baud Rate	9600bps
Protocol	VISCA
Video Format	1080i50
Analog Video Format	YPbPr
Mounting Type	Stand

Sw1 Settings

No 1~6 are used to set address for camera, the DIPs adopt binary system. No. 7 is used to set analog video format. No. 8 is used to set mounting type. Refer to page 22 for details.

Sw2 Settings

No. 1 and 2 of SW2 is used to set protocol; no. 3 and 4 is used to set baud rate; no. 5, 6, 7, 8 is used to set video output format. Refer to below chart for details:

SW2						
DIP No.		1	2			
Protocol		OFF	OFF	VISCA		
		ON	OFF	PELCO- D		
		OFF	ON	PELCO- P		
		ON	ON	Reserved		
DIP No.		3	4			
Baud Rate(bps)		OFF	OFF	2400		
		ON	OFF	4800		
		OFF	ON	9600		
		ON	ON	38400		
DIP No.		5	6	7	8	
Video Format		OFF	OFF	OFF	OFF	1080p60
		ON	OFF	OFF	OFF	1080p50

		OFF	ON	OFF	OFF	1080i60
		ON	ON	OFF	OFF	1080i50
		OFF	OFF	ON	OFF	720p60
		ON	OFF	ON	OFF	720p50
		OFF	ON	ON	OFF	1080p30
		ON	ON	ON	OFF	1080p25
		OFF	OFF	OFF	ON	720p30
		ON	OFF	OFF	ON	720p25
	Only available for 30X model	OFF	ON	OFF	ON	1080p59.94
		ON	ON	OFF	ON	1080p29.97
		OFF	OFF	ON	ON	1080i59.94
		ON	OFF	ON	ON	720p59.94
		OFF	ON	ON	ON	720p29.97

When No.5~8 is all ON, video format can be switched by calling preset, Refer to below chart for details:

Preset No.		Function
	93	Cruise, camera switches among saved 0~29 presets repeatedly and sequentially in fixed interval.
	95	Get into menu
	96	Delete all presets
	99	System reboot
	100	1920X1080p50
	101	1920X1080p25
	102	1920X1080i50
	103	1280X720p50
	104	1280X720p25
	105	1920X1080p60
	106	1920X1080p30
	107	1920X1080i60
	108	1280X720p60
109	1280X720p30	
Only available for 30X model	110	1920X1080p59.94
	111	1920X1080p29.97
	112	1920X1080i59.94
	113	1280X720p59.94
	114	1280X720p29.97

When HD video output format is set as 1080p60, 1080p30, 1080i60, 720p30 or 720p60, relative SD video format is NTSC; when HD video output format is set as 1080p50, 1080p25, 1080i50, 720p25 or 720p50, relative SD video format is PAL.

Remote Controller

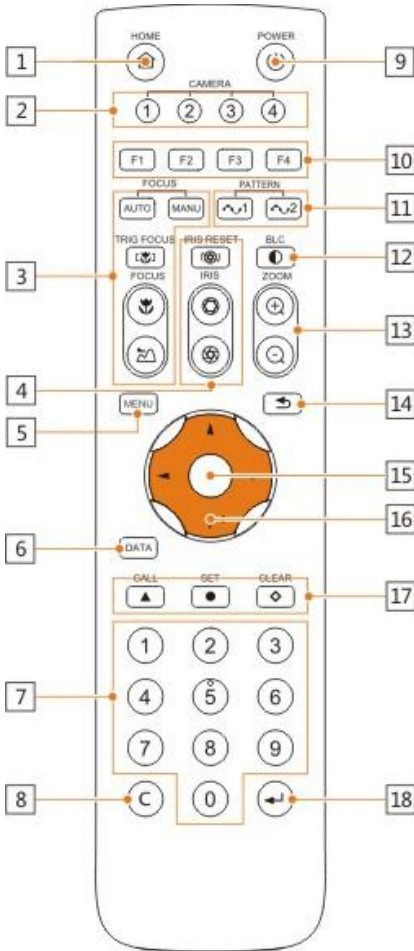

1 HOME

Press **HOME** button, camera moves to initial position where both pan and tilt angle is zero.

2 Camera Selection Button

Used to switch among 4 cameras, press 1-4 number buttons to control cameras with 1-4 addresses respectively. For example, press button 1 to control the camera with address 1.

3 Focus



Press "AUTO" button to switch to Auto Focus, press "MANU" button to switch to Manual Focus mode.

"" button to Focus Near

"" button to Focus Far

"" button to Auto Focus once every time it is pressed, then switch back to Manual Focus mode.

4 Iris

Press "" button to reset iris value to default. "" button to Iris Open

"" button to Iris Close.

5 Menu

Press **MENU** button to enter / exit menu.

6 Data

Press **DATA** button to set on / off the display of pan tilt angle, zoom times and other prompt message.

7 Number Keys

Used to input numbers, for example, preset number.

8 Cancel

To cancel numbers input

9 Power

After the camera has been connected to power source, in none-menu status, press this button to turn on / off the camera.

10 Reserved Buttons (F1, F2, F3, F4)

These buttons are reserved for future use.

11 Pattern

Used to activate Pattern Scan1 and Pattern Scan2.

12 BLC

Used to open / close back light compensation.

13 Zoom

Used to adjust zooming times.

“” button to zoom in

“” button to zoom out.

14 Back

Press “” button to go back to previous menu.





15 OK

In None-menu status: press this button to switch among pan / tilt control speeds.

In Menu status: get into relative menu option after it has been selected.

16 Direction / Menu Operation

In None-menu status, press these four buttons to pan left/right and tilt up/down.

In Menu status:  or  button to select among menu options,  or  to change option / value.

17 Preset Setting

“” button to call a preset.

Input number key(s), and then press this button to call a preset.

“” button to set a preset.

Move the camera to a specific position, adjust focus value and etc, and then press this button to set a preset.

“” button to clear a preset.

Input number key(s), and then press this button to clear a preset.

18 Enter

After inputting numbers, press this button to confirm.

CONNECTIONS

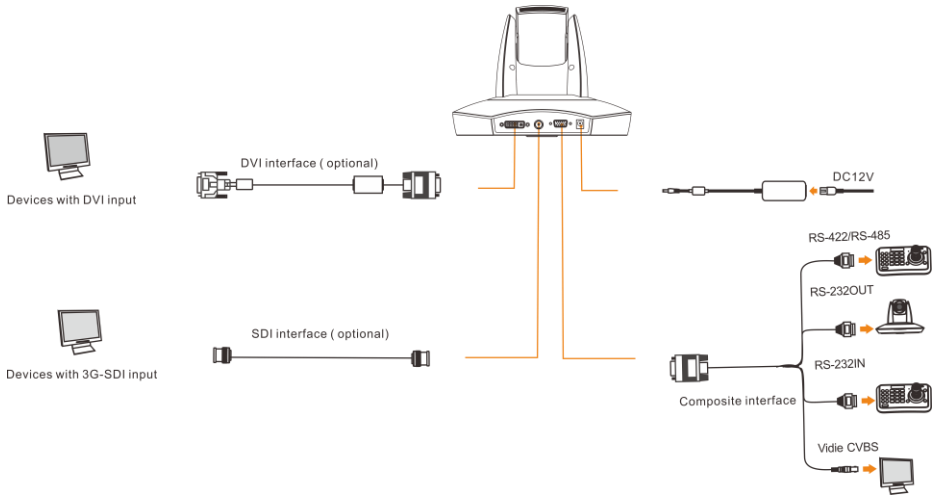

Note

If preset 0 has been saved, after powered on, camera moves to preset 0 automatically; if preset 0 has not been saved, after powered on, camera moves to Home position, where both pan and tilt angle is zero and zooming time is 1x.

INSTALLATION

The camera has 3 installation types: desktop, ceiling, wall mount installations.

Note

Before installing, make sure there is enough space to install the camera and its parts.

Make sure the installed place is strong and safe enough to hold the camera and relative parts, it is suggested that the installed place can withstand 4 times the weight of the camera and its relative parts.

Desktop Mount Installation

1. Put the camera on a flat surface. In case the camera has to be placed on an inclined surface, make sure the cline angle is less than 15 degrees to ensure proper pan /tilt operation.

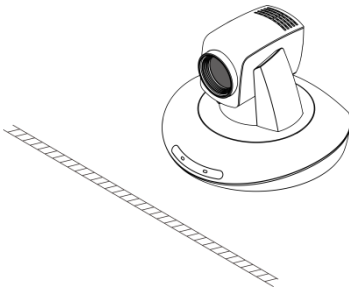

Note

- Take effective measures to avoid camera from dropping.
- Do not grab the camera head when carrying.
- Do not rotate the camera head with hand. It may cause malfunction to the camera.

Wall Mount Installation

Not Supplied With Camera

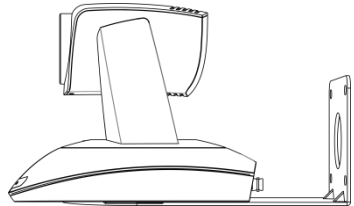

1. According to diameter and position of the 4 installation holes (As shown below) on the bracket, drill 4 holes on the wall and fix the bracket onto the wall by using 4 screws which should be prepared by you.

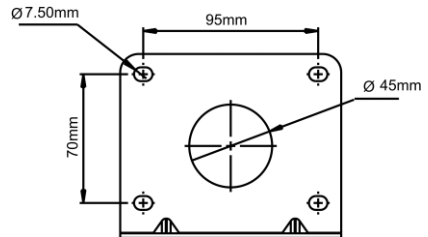

2. Before fixing the camera, set the DIP switches of the camera correctly.

- Use inch screws to fix the camera on the bracket, fix the limit screw according to actual requirement, and make sure the camera is tightly fixed onto the bracket before your hands leave the camera.

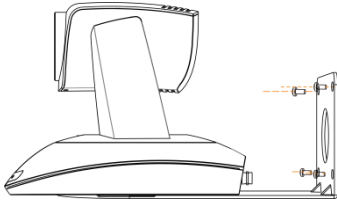

- Fix the mounting plate onto the ceiling or cement roof with 3 screws which should be prepared by you.

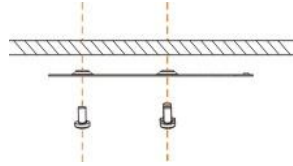

- Before fixing the camera, set the DIP switches of the camera correctly.

- Use 3 screws to fix the camera on the ceiling mount plate.

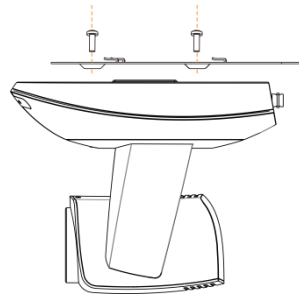

Ceiling Mount Installation

Not Supplied With Camera

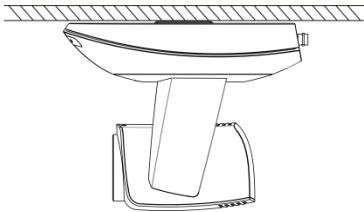

- According to diameter and position of the 3 installation hole (as shown below), drill 3 holes on the ceiling or cement roof correspondingly.

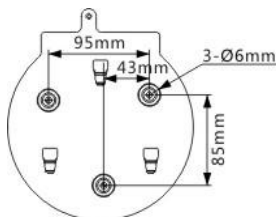

- Push forward camera's bottom slide according to the mounting plate's bottom slide until they reach their limit. Fix the ceiling mount plate and camera's bottom plate with M3×8 screws.

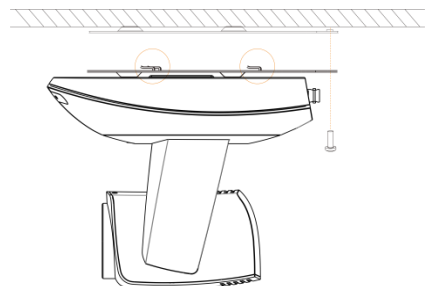

MENU SETTINGS

Menu Configuration

<VIDEO> Refer to Page 15	SHARPNESS	0, 1, 2, 3, 4, 5, 6, 7, 8, 9, 10, 11, 12, 13, 14, 15
	BRIGHTNESS	-7, -6, -5, -4, -3, -2, -1, 0, +1, +2, +3, +4, +5, +6, +7
	CONTRAST	-7, -6, -5, -4, -3, -2, -1, 0, +1, +2, +3, +4, +5, +6, +7
	SATURATION	-7, -6, -5, -4, -3, -2, -1, 0, +1, +2, +3, +4, +5, +6, +7
	HUE	-7, -6, -5, -4, -3, -2, -1, 0, +1, +2, +3, +4, +5, +6, +7
	2DNR LEVEL	LOW, MID, MAX, OFF
	3DNR LEVEL	LOW, MID, MAX, OFF
	WIDE DYNAMIC	ON, OFF

<EXPOSURE>

Refer to
Page 15

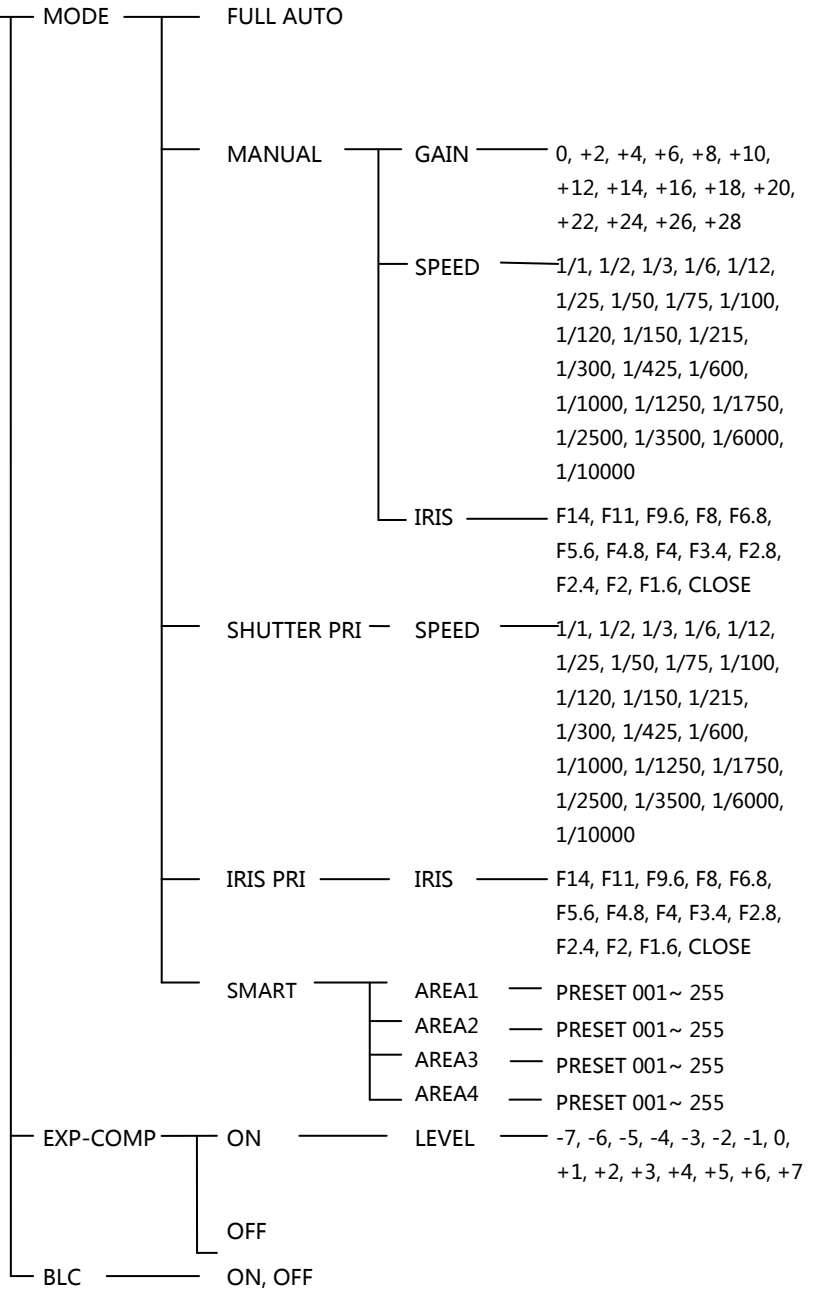

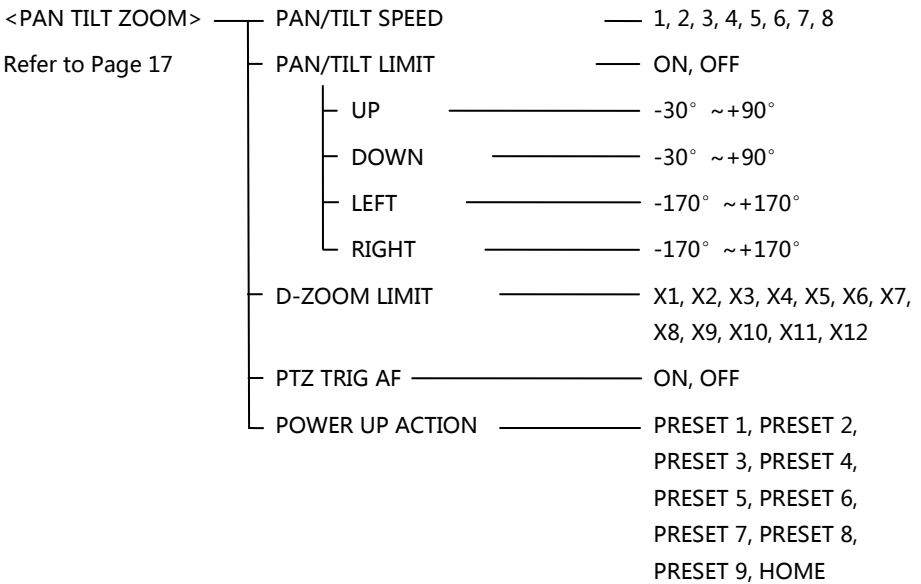
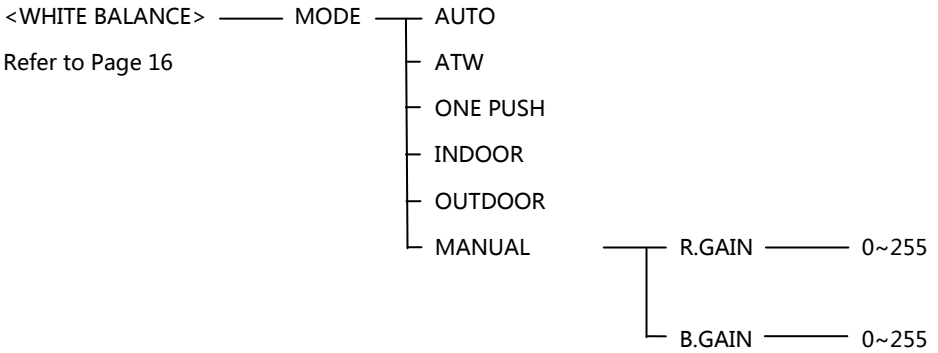

<SYSTEM> Refer to Page 18	DISPLA	INFO	_____	ON, OFF
	RATIO	SPEED	_____	ON, OFF
	PRESET	FREEZE	_____	ON, OFF
	CVBS	OUTPUT	_____	SQUEEZE, CROP, LETTER BOX
	RS422	PORT	_____	HALF-DUPLEX-1, HALF-DUPLEX-2, FULL-DUPLEX

<STATUS> Refer to Page 18	ADDRESS	1
	PROTOCOL	VISCA
	BAUDRATE	9600
	VIDEO FORMAT	1080i50
	DVI-I OUTPUT	YPBPR
	MOUNT MODE	STAND
	FIRMWARE VER	V1.2.5

<RESTORE DEFAULTS> Refer to Page 18

Menu Explanation

Main Menu

Press **MENU** button to enter / exit menu.

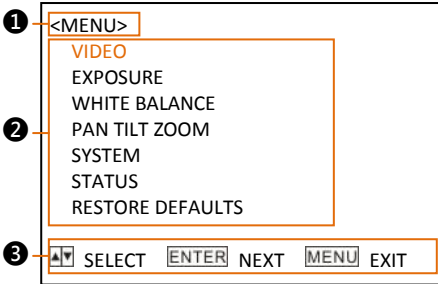

1 Menu Hint

It displays currently selected menu option.

2 Menu Options

It displays options under current menu hint.

Press ▲ or ▼ button to select among menu options, once font of options turned from white color to yellow color, it indicates the menu has been elected, press **OK** button to get into this menu.

3 Prompt Message

“◀▶ SELECT” indicates it is possible to press ▲ or ▼ button to select menu options.

“ENTER NEXT” indicates it is possible to press **OK** button to enter next level menu.

“MENU EXIT” indicates it is possible to press **MENU** button to exit menu.

Submenus

From main menu, navigate to select

<EXPOSURE> menu, press **OK** to enter.

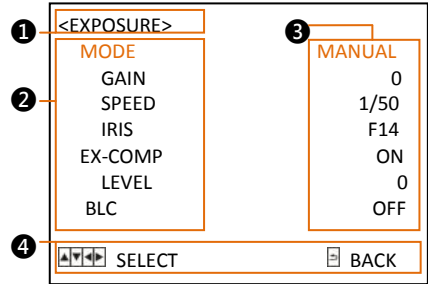

1 Menu Hint

It displays currently selected menu option.

2 Menu Options

It displays options under current menu hint.

Press ▲ or ▼ button to select among menu options, once font of options turned from white color to yellow color, it indicates the menu has been elected, press **OK** button to get into this menu.

3 Manual Exposure

Press ◀ or ▶ button to change value.

4 Prompt Message

“◀▶ SELECT” indicates it is possible to press ▲ or ▼ to select menu options, press ◀ or ▶ to change value

“BACK” indicates it is possible to press **BACK** to return to previous menu.

Video

VIDEO menu is used to change video value.

<VIDEO>	
SHARPNESS	8
BRIGHTNESS	+5
CONTRAST	+2
SATURATION	-5
HUE	0
2DNR LEVEL	OFF
3DNR LEVEL	OFF
WIDE DYNAMIC	OFF
SELECT	BACK

Available Options:

SHARPNESS: 0, 1, 2, 3, 4, 5, 6, 7, 8, 9, 10, 11, 12, 13, 14, 15.

BRIGHTNESS: -7, -6, -5, -4, -3, -2, -1, 0, +1, +2, +3, +4, +5, +6, +7.

CONTRAST: -7, -6, -5, -4, -3, -2, -1, 0, +1, +2, +3, +4, +5, +6, +7.

SATURATION: -7, -6, -5, -4, -3, -2, -1, 0, +1, +2, +3, +4, +5, +6, +7.

HUE: -7, -6, -5, -4, -3, -2, -1, 0, +1, +2, +3, +4, +5, +6, +7.

2DNR LEVEL: ON, OFF (20X model).

LOW, MID, MAX, OFF (30X model).

If camera displays color image, it is suggested to turn off the 2DNR level, otherwise, the video trails will be generated. The higher the level is, the better is the noise reduction

performance, but more video trails will be generated.

3DNR LEVEL: AUTO, 1, 2, 3, 4, OFF (20X model).

LOW, MID, MAX, OFF (30X model).

WIDE DYNAMIC: ON, OFF.

Exposure

EXPOSURE menu is used to adjust exposure value.

<EXPOSURE>	
MODE	MANUAL
GAIN	0
SPEED	1/50
IRIS	F14
EXP-COMP LEVEL	0
BLC	ON
SELECT	BACK

Available Options:

MODE:

FULL AUTO: Gain, Shutter Speed and Iris value are adjusted automatically accordingly to working environment.

MANUAL: manually adjust Gain, Shutter Speed and Iris

GAIN: 0, +2, +4, +6, +8, +10, +12, +14, +16, +18, +20, +22, +24, +26, +28, +30 (20X model).

0, +2, +4, +6, +8, +10, +12, +14, +16, +18, +20, +22, +24, +26, +28 (30X).

SPEED: 1/1, 1/2, 1/3, 1/6, 1/12, 1/25, 1/50, 1/75, 1/100, 1/120, 1/150, 1/215, 1/300, 1/425, 1/600, 1/1000, 1/1250, 1/1750, 1/2500, 1/3500, 1/6000, 1/10000.

IRIS: F14, F11, F9.6, F8, F6.8, F5.6, F4.8, F4, F3.4, F2.8, F2.4, F2, F1.6, CLOSE.

SHUTTER PRI: Gain and Iris value are adjusted automatically according to working environment; shutter speed value is adjustable manually.

SPEED: 1/1, 1/2, 1/3, 1/6, 1/12, 1/25, 1/50, 1/75, 1/100, 1/120, 1/150, 1/215, 1/300, 1/425, 1/600, 1/1000, 1/1250, 1/1750, 1/2500, 1/3500, 1/6000, 1/10000.

IRIS PRI: Gain and shutter speed value are adjusted automatically according to working environment; Iris value is adjustable manually.

IRIS: F14, F11, F9.6, F8, F6.8, F5.6, F4.8, F4, F3.4, F2.8, F2.4, F2, F1.6, CLOSE.

BRIGHT PRI: manually adjust bright of image.

BRIGHT: 0, 1, 2, 3, 4, 5, 6, 7, 8, 9, 10, 11, 12, 13, 14, 15, 16, 17, 18, 19, 20, 21, 22, 23, 24, 25, 26, 27 (20X model).

EXP-COMP: once EXP-COMP is set as On, below level options become available -7, -6, -5, -4, -3, -2, -1, 0, +1, +2, +3, +4, +5, +6, +7 is the maximum compensation value for bright,

-7 is the maximum compensation value for dark.

BLC : ON, OFF

Backlight compensation (BLC) is video gain done automatically to correct the exposure of subjects that are in front of a bright light source.

ANTI-FLICKER (OFF, 50Hz, 60Hz): To avoid video flicker at power systems of different frequency. (20X model)

White Balance

WHITE BALANCE menu is used to select from white balance modes. Available options:

< WHITE BALANCE >	
MODE	MANUAL
R.GAIN	1
B.GAIN	128
SELECT	BACK

MODE: AUTO, ATW(auto tracking), ONE PUSH, INDOOR, OUTDOOR, MANUAL, SODIUM LAMP (20X model), FLUO LAMP (20X model).

“ONE PUSH”: when in “ONE PUSH TRIGGER” mode, aim the camera at a pure white object (say a white paper), then press OK button.

“MANUAL” mode: R.GAIN and B. GAIN value can be chosen from 0~255.

Pan/Tilt/Zoom

PAN/TILT/ZOOM is used to change pan/tilt/zoom value, available options:

<PAN TILT ZOOM>	
PAN/TILT SPEED	8
PAN/TILT LIMIT	ON
UP	+90
DOWN	-30
LEFT	+170
RIGHT	-170
D-ZOOM LIMIT	X4
PTZ TRIG AF	OFF
POWER UP ACTION	HOME
SELECT	BACK

PAN/TILT SPEED: 1, 2, 3, 4, 5, 6, 7, 8 the bigger the number is, the faster the speed is. The speed is the fastest when in 1x zoom compared to other zooming times.

PAN/TILT LIMIT: ON/OFF, once it is set as ON, below limit value can be set

UP: -30°~+90°, adjustable every 1°;

DOWN: -30°~+90°, adjustable every 1°;

LEFT: -170°~+170°, adjustable every 1°;

LIGHT: -170°~+170°, adjustable every 1°.

D-ZOOM LIMIT: X1, X2, X3, X4, X5, X6, X7, X8, X9, X10, X11, X12.

PTZ TRIG AF: Turn ON / OFF the auto focus when the camera pans / tilts / zooms.

POWER UP ACTION: PRESET 1, PRESET 2, PRESET 3, PRESET 4, PRESET 5, PRESET 6, PRESET 7, PRESET 8, PRESET 9, HOME.

System

<SYSTEM>	
DISPLAY INFO	OFF
RATIO SPEED	ON
PRESET FREEZE	OFF
CVBS OUTPUT	SQUEEZE
RS422 PORT	HALF-DUPLEX-1
SELECT	BACK

DISPLAY INFO: Turn ON / OFF display of pan / tilt angle and prompt message.

RATIO SPEED: When RATIO SPEED is set as ON, at telephoto zoom settings, the pan and tilt speeds will be slower for a given amount of joystick deflection than at wide zoom settings. This keeps the image from moving too fast on the monitor when there is a large amount of zoom.

PRESET FREEZE: When it is on, during a regular preset call, the video will be frozen at point A till Point B. At Point B, the video will be displayed normally.

CVBS OUTPUT : LETTER BOX, CROP, SQUEEZE.

LETTER BOX: add a blank area in the upper and lower portion of the image to display video in 16:9 ratio, so can show without distortion in 4:3 ratio monitor.

CROP: cut the left and the right side of 16:9 ratio image to get 4:3 ratio image.

SQUEEZE: compress the video signal horizontally to get 16:9 ratio image without distortion.

RS422 PORT: FULL-DUPLEX,

HALF-DUPLEX-1, HALF-DUPLEX-2

FULL-DUPLEX:RS422 full duplex mode, connecting R + , R- , T + , T- interface of the camera to control devices.

HALF-DUPLEX-1:RS485 half duplex mode, in VISCA protocol, after executing the command message, the camera does not return confirmation / completion / error messages.

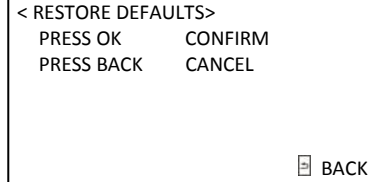

HALF-DUPLEX-2:RS485 half duplex mode, in VISCA protocol, after executing the command message, the camera return confirmation / completion / error messages.

Restore Defaults



```
< RESTORE DEFAULTS>
PRESS OK      CONFIRM
PRESS BACK    CANCEL

[←] BACK
```

RESTORE DEFAULTS option is used to reset all menus to default value. Press  to confirm or press  to cancel and return to previous menu.

Status

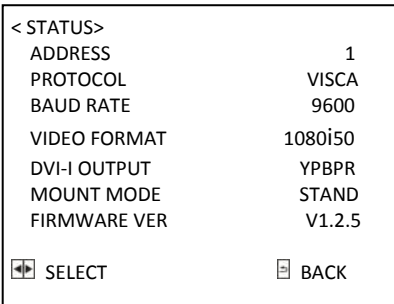

```
< STATUS>
ADDRESS          1
PROTOCOL         VISCA
BAUD RATE        9600
VIDEO FORMAT     1080i50
DVI-I OUTPUT     YPBPR
MOUNT MODE       STAND
FIRMWARE VER     V1.2.5

[←] SELECT      [←] BACK
```

It displays current camera's address, protocol, baud rate, video format, mount mode and software version number.

ANNEX 1 TECHNICAL SPECIFICATIONS

Items	Value	
Image Sensor	1/2.8" CMOS, 2.14 megapixel	
Signal System (HD)	1080p60, 1080p59.94, 1080p50, 1080p30, 1080p29.97, 1080p25, 1080i60, 1080i59.94, 1080i50, 720p60, 720p59.94, 720p50, 720p30, 720p29.97, 720p25	1080p60, 1080p50, 1080p30, 1080p25, 1080i60, 1080i50, 720p60, 720p50, 720p30, 720p25
Focal Lens	f=4.3mm-129.0mm	f=4.7mm-94.0mm
Iris	F1.6-F4.7	F1.6-F3.5
Optical Zoom	30x	20x
Digital Zoom	12x	
Horizontal Viewing Angle	63.7°-2.3°	59.5°-2.9°
Focus System	Auto, Manual, PTZ trigger, One push trigger	
Min. Illumination	0.0013lux(color), 0.0008 lux (B/W)	0.5lux(color), 0.1lux(B/W)
Shutter Speed	1/1 to 1/10,000s	
Gain	Auto /Manual	
White Balance	Auto, Indoor, Outdoor, One push, Manual, Auto tracking	
Wide Dynamic	Yes	
Exposure Control	Auto, Manual, Shutter Priority, Iris Priority, Smart	
S/N	≥50dB	
Back Light Compensation	Yes	
Pan Angle	-170°~+170°	
Tilt Angle	-30°~+90°	
Pan Speed	0.1°~120°/S	
Tilt Speed	0.1°~90°/S	
Preset Number	256	
OSD	Yes	
Image Flip	Yes	
HD video output	DVI-I(for DVI-D, HDMI, YPbPr, VGA, 5-BNC), 3G-SDI	
SD Video Output	CVBS	
Control Interface	RS-232IN, RS-232OUT, RS-422, RS-485	
IR Throughout Output	1 channel IR throughout output	
Protocol	VISCA(daisy chain) / PELCO-P / PELCO-D	
Address	0~63	
Power	DC12V	
Power Consumption	<20W	
Operating Temperature	0°C~+40°C	
Storage Temperature	-20°C~+60°C	
Dimensions (W×H×D)	220mm×202mm×162mm	
Weight	1.7KG	
Body color	grey	

ANNEX 2 SIZE AND DIMENSION

Front

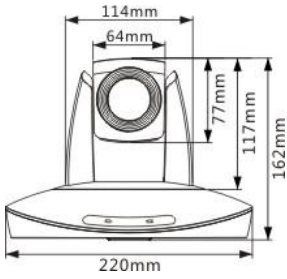

Rear

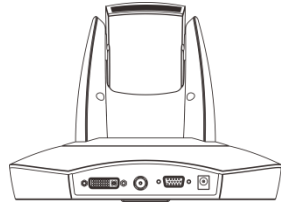

Side

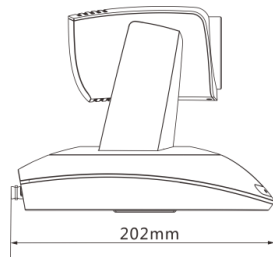

Top

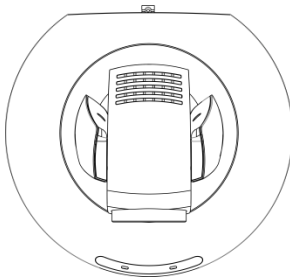

Bottom

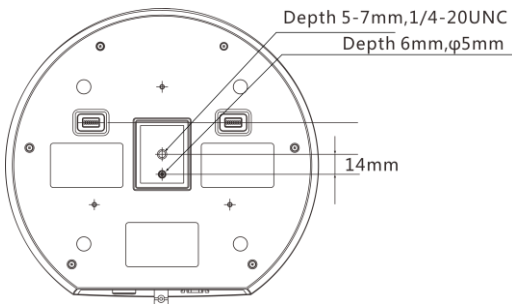

ANNEX 3 SW1 DEFINITION

Address	DIP No.					
	1	2	3	4	5	6
	OFF	OFF	OFF	OFF	OFF	OFF
1	ON	OFF	OFF	OFF	OFF	OFF
2	OFF	ON	OFF	OFF	OFF	OFF
3	ON	ON	OFF	OFF	OFF	OFF
4	OFF	OFF	ON	OFF	OFF	OFF
5	ON	OFF	ON	OFF	OFF	OFF
6	OFF	ON	ON	OFF	OFF	OFF
7	ON	ON	ON	OFF	OFF	OFF
8	OFF	OFF	OFF	ON	OFF	OFF
9	ON	OFF	OFF	ON	OFF	OFF
10	OFF	ON	OFF	ON	OFF	OFF
11	ON	ON	OFF	ON	OFF	OFF
12	OFF	OFF	ON	ON	OFF	OFF
13	ON	OFF	ON	ON	OFF	OFF
14	OFF	ON	ON	ON	OFF	OFF
15	ON	ON	ON	ON	OFF	OFF
16	OFF	OFF	OFF	OFF	ON	OFF
17	ON	OFF	OFF	OFF	ON	OFF
18	OFF	ON	OFF	OFF	ON	OFF
19	ON	ON	OFF	OFF	ON	OFF
20	OFF	OFF	ON	OFF	ON	OFF
21	ON	OFF	ON	OFF	ON	OFF
22	OFF	ON	ON	OFF	ON	OFF
23	ON	ON	ON	OFF	ON	OFF
24	OFF	OFF	OFF	ON	ON	OFF
25	ON	OFF	OFF	ON	ON	OFF
26	OFF	ON	OFF	ON	ON	OFF
27	ON	ON	OFF	ON	ON	OFF
28	OFF	OFF	ON	ON	ON	OFF
29	ON	OFF	ON	ON	ON	OFF
30	OFF	ON	ON	ON	ON	OFF
31	ON	ON	ON	ON	ON	OFF
32	OFF	OFF	OFF	OFF	OFF	ON
33	ON	OFF	OFF	OFF	OFF	ON
34	OFF	ON	OFF	OFF	OFF	ON
35	ON	ON	OFF	OFF	OFF	ON
36	OFF	OFF	ON	OFF	OFF	ON
37	ON	OFF	ON	OFF	OFF	ON
38	OFF	ON	ON	OFF	OFF	ON
39	ON	ON	ON	OFF	OFF	ON

40	OFF	OFF	OFF	ON	OFF	ON
41	ON	OFF	OFF	ON	OFF	ON
42	OFF	ON	OFF	ON	OFF	ON
43	ON	ON	OFF	ON	OFF	ON
44	OFF	OFF	ON	ON	OFF	ON
45	ON	OFF	ON	ON	OFF	ON
46	OFF	ON	ON	ON	OFF	ON
47	ON	ON	ON	ON	OFF	ON
48	OFF	OFF	OFF	OFF	ON	ON
49	ON	OFF	OFF	OFF	ON	ON
50	OFF	ON	OFF	OFF	ON	ON
51	ON	ON	OFF	OFF	ON	ON
52	OFF	OFF	ON	OFF	ON	ON
53	ON	OFF	ON	OFF	ON	ON
54	OFF	ON	ON	OFF	ON	ON
55	ON	ON	ON	OFF	ON	ON
56	OFF	OFF	OFF	ON	ON	ON
57	ON	OFF	OFF	ON	ON	ON
58	OFF	ON	OFF	ON	ON	ON
59	ON	ON	OFF	ON	ON	ON
60	OFF	OFF	ON	ON	ON	ON
61	ON	OFF	ON	ON	ON	ON
62	OFF	ON	ON	ON	ON	ON
63	ON	ON	ON	ON	ON	ON

DIP No.	7	
Analog Video Format	ON	VGA, 5-BNC (3G-SDI or YPbPr output is not supported)
	OFF	YPbPr
DIP No.	8	
Mounting Type	ON	Ceiling
	OFF	Stand

TROUBLESHOOTING

Problem	Possible Cause	Solution
No action or image after powered on	Power supply failure	Check power supply
	Power adapter damaged	Replace power adapter
	Power cable connection got loosen	Check & reconnect
No self-testing after powered on, or with motor noise	Not enough power supply	Check & reconnect power cable connection
	Mechanical failure	Repair
Not controllable from remote controller	Low battery of remote controller	Change battery for remote controller
	Exceed remote control distance	Control within distance of 8M
After power on, self-test successfully, but not controllable	Wrong address / protocol / baud rate	Check & set again
	Wrong connection or open circuit of RS-485/RS-422 or RS-232 cable	Check & reconnect
Video loss when pans / tilts / zooms	Not enough power supply	Check & reconnect power cable
	Video cable not properly connected	Replace with a good video cable
Video captured after connected to digital video interface of a capture device is not good as the video captured after connected directly analog video interface of the capture device	Different video capture devices have different video capturing performance, image quality maybe worse after it has been converted from analog to digital	Consult video capture device supplier for more information

The user manual is only for a reference, if there are any changes or differences, please ask for the latest version from your supplier

CA/YF-HMC-ZD-021

Y06020801010