

4K PTZ Color Video Camera

User Manual V1.0

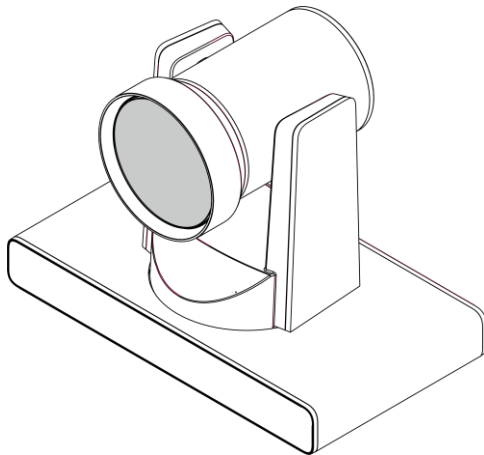

SAFETY NOTICE-IMPORTANT

The following important notes must be followed carefully to run the camera and respective accessories in total safety. The camera and relative accessories are called video system in this section.

- Before installing the camera, please read this manual carefully. Please follow installation instructions indicated in this manual during installation. Please keep this manual for future use.
- The installation should be performed by qualified service personnel or system installers in accordance with all local rules.
- Before powering on the camera, please check the power voltage carefully. Make sure that you are using the correct power source.
- Please put the power cable, video cable and control cable in safe place.
- Do not operate the camera beyond the specified temperature and humidity. Working temperature range of the camera is between 0°C and +40°C. The ambient humidity range is less than 90 % .
- During transporting, avoid violent shake or force to the camera.
- To prevent electric shock, do not remove screws or housing of the camera. There are no self-serviceable parts inside. Refer to qualified service personnel for servicing.
- Video cable and RS485 cable should be kept far away from other cables. Shielded and independent wiring is necessary for video and control cables.
- Never aim the lens of the camera at the sun or other extremely bright objects. Otherwise, it may cause damage.
- When cleaning the camera, please use soft cloth. If the camera is very dirty, wipe it off gently with a soft cloth moistened with a weak solution of water and a neutral kitchen detergent. Wring all liquid from the cloth before wiping the camera, then wipe off all remaining dirt with a soft, dry cloth. Use lens cleaning paper to clean the lens.

- Do not move the camera head manually. In doing so would result in malfunction of the camera. Do not hold the camera head when carrying the video camera.
- This camera is for indoor use only. It is not designed for outdoor use.
- Make sure the camera is not directly exposed to rain and water.
- Make sure the camera is far away from area where radiation, X-rays, strong electric waves, or magnetism is generated.

CONTENTS

ABOUT THE PRODUCT	1
FEATURES	1
LIST OF PARTS & ACCESSORIES	1
MAIN PARTS & INTERFACES	2
DIP SWITCHES SETTINGS	4
OLED DISPLAY PANEL	4
REMOTE CONTROLLER	5
INSTALLATION	7
DESKTOP MOUNT INSTALLATION	7
WALL MOUNT INSTALLATION (OPTIONAL)	7
CONNECTIONS	8
MENU SETTINGS	9
MENU CONFIGURATION	9
MENU EXPLANATION	13
VIDEO	14
EXPOSURE	14
COLOR	15
PAN/TILT/ZOOM	16
SYSTEM	16
STATUS	17
RESTORE DEFAULTS	17
LIST OF SPECIAL PRESET COMMANDS	17
SMART CMS APPLICATION SOFTWARE GUIDE	18
NETWORK CONNECTION	18
CLIENT SOFTWARE INSTRUCTION	21
ANNEX 1 TECHNICAL SPECIFICATIONS	32
ANNEX 2 SIZE AND DIMENSION	34
ANNEX 3 SW1 DEFINITION	35
TROUBLESHOOTING	37

ABOUT THE PRODUCT

Features

- Latest high quality CMOS image sensor, max. support 3840x2160@30fps video output;
- High quality 4K ultra wide angle lens, 12x optical zoom, maximum field of view angle up to 82.6°;
- Advanced 2D/3D image noise reduction algorithm, noise control is excellent;
- Ultra HD 4K uncompressed digital video output;
- HDMI, 3G-SDI, HDBaseT (optional), network interface output HD digital video at the same time;
- Dual stream, supporting multi-levels configuration of video quality;
- 1 channel audio input and 1 channel output;
- Max. 64G TF card for local storage;
- Precise driving system with high reliability and precision;
- Multiple protocols & control interfaces and VISCA Daisy chain;
- With IR remote controller;
- Built-in OLED to display the system status, IP address and other necessary information;
- OSD menu;

- Smart AE technology to effectively avoid the interference of complicated lights from projectors, monitors etc;

List Of Parts & Accessories

When you open the box, check all accessories according to the packing list.

Camera (1)

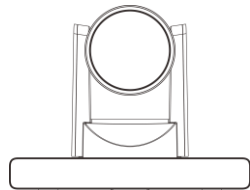

Power Adapter (1)

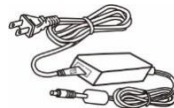

Remote Controller (1)

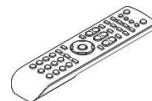

RS-232 Control Cable (1)



Software Disc (1)

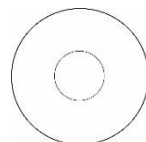

Main Parts & Interfaces

Camera

Front View

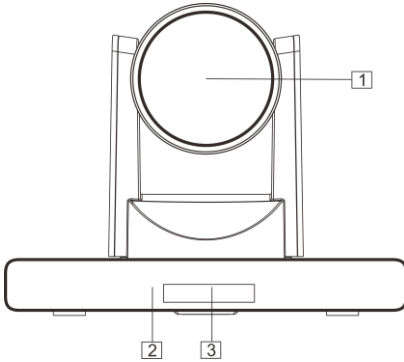

- 1 Camera Module
- 2 Remote Controller Indicator
- 3 OLED Display Panel

Rear View

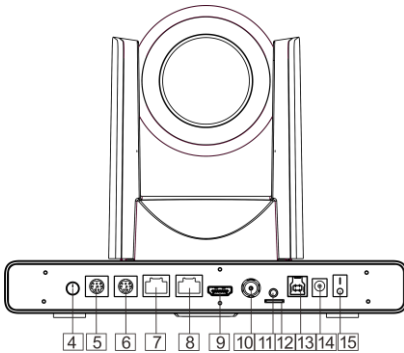

- 4 Video Format Selection Switch
- 5 RS-232 IN
- 6 RS-232 OUT
- 7 Ethernet
- 8 HDBaseT (optional)

- 9 HDMI
- 10 SDI
- 11 Audio
- 12 TF Card Slot
- 13 USB 3.0 (reserved)
- 14 Power (DC12V)
- 15 Power Switch

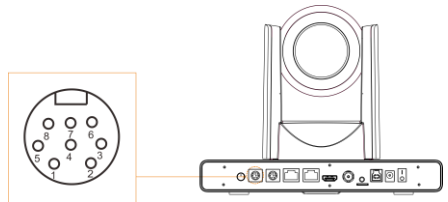

RS-232 IN/IR Pin Definition	
Number	Definition
1	/
2	/
3	232-TX
4	GND
5	232-RX
6	GND
7	IR
8	/

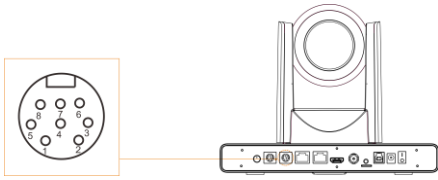

RS-232 OUT/RS-485 Pin Definition	
Number	Definition
1	/
2	/
3	232-TX
4	GND
5	232-RX
6	GND
7	485+
8	485-

Bottom View

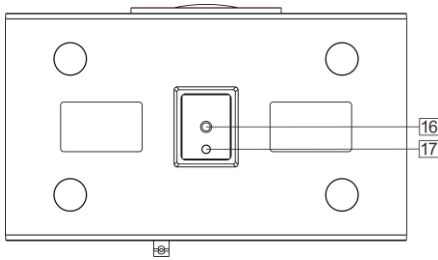

16 Mounting Hole

1/4" screw thread for fixing camera.

17 Locating Hole

To define installation direction of camera.

DIP Switches Settings

Before installing and operating the camera, set the video output format etc through DIP switches. The camera has 15-digit DIP switches, as below:

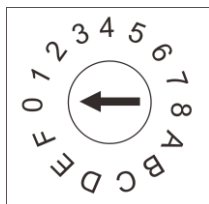

Settings

No. 0~7 are used to set different video formats; No. 8~E are reserved for future use; when DIP switch to No. F, the video format can be programmed by OSD menu (refer to page 15), or changing video formats through special presets (refer to page 16).

Video Format DIP Definition			
0	1080P60	8	--
1	1080P50	9	--
2	1080I60	A	--
3	1080I50	B	--
4	720P60	C	--
5	720P50	D	4KP30
6	1080P30	E	4KP25
7	1080P25	F	set by OSD menu

NOTE

PTZ reboot is necessary for the new setting to take effect.

OLED Display Panel

- In different states, OLED will display the camera a status;
- "Booting..." is displayed during power-on;
- After the power-on self-test, the current output video format is displayed (such as: "4KP30");
- When the camera interface is connected to the network, the current IP address is displayed (such as: "192.168.1.180");
- When you upgrade the firmware, the messages "Updating...", "Downloading..." are displayed depending on the status of the upgrade process.

Remote Controller

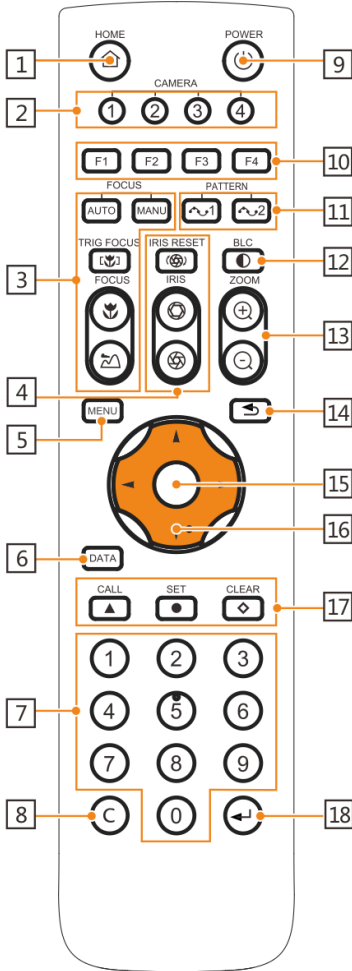

1 HOME

Press **HOME** button, camera moves to initial position.

2 Camera Selection Button

Used to switch among 4 cameras, press 1-4 number buttons to control cameras with 1-4 addresses respectively. For example, press button 1 to control the camera with address 1.

3 Focus



Press "AUTO" button to switch to Auto Focus, press "MANU" button to switch to Manual Focus mode.

"" button to Focus Near;

"" button to Focus Far;

"" button to Auto Focus once every time it is pressed, then switch back to Manual Focus mode.

4 Iris

Press "" button to reset iris (image brightness) value to default. "" button to Iris Open (brighter image).

"" button to Iris Close (darker image).

5 Menu

Press **MENU** button to enter / exit menu.

6 Data

Reserved.

7 Number Keys

Used to input numbers, for example, preset number.

8 Cancel

To cancel numbers input.

9 Power

After the camera has been connected to power source, in none-menu status, press this button to turn on / off the camera.

10 Reserved Buttons (F1, F2, F3, F4)

These buttons are reserved for future use.

11 Pattern

Reserved.

12 BLC

Used to open / close back light compensation.

13 Zoom

Used to adjust zooming times.

“+” button to zoom in;

“-” button to zoom out.

14 Back

Press “” button to go back to previous menu.

15 OK

In None-menu status: press this button to switch among pan / tilt control speeds.

In Menu status: get into relative menu option after it has been selected.

16 Direction / Menu Operation

In None-menu status, press these four buttons to pan left/right and tilt up/down.

In Menu status: ▲ or ▼ button to select among menu options, ◀ or ▶ to change option / value.

17 Preset Setting

“▲” button to call a preset.

Input number key(s), and then press this button to call a preset.

“●” button to set a preset.

Move the camera to a specific position, adjust focus value and etc, and then press this button to set a preset.

“◇” button to clear a preset.

Input number key(s), and then press this button to clear a preset.

18 Enter

After inputting numbers, press this button to confirm.

INSTALLATION

The camera has 2 installation types: desktop, wall mount installations (optional).

Note

Before installing, make sure there is enough space to install the camera and its parts.

Make sure the installed place is strong and safe enough to hold the camera and relative parts, it is suggested that the installed place can withstand 4 times the weight of the camera and its relative parts.

Desktop Mount Installation

1. Put the camera on a flat surface. In case the camera has to be placed on an inclined surface, make sure the cline angle is less than 15 degrees to ensure proper pan /tilt operation.

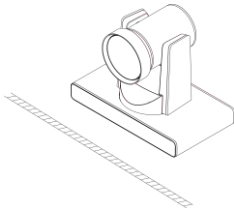

Note

- Take effective measures to avoid camera from dropping.
- Do not grab the camera head when carrying.
- Do not rotate the camera head with hand. It may cause malfunction to the camera.

Wall Mount Installation (Optional)

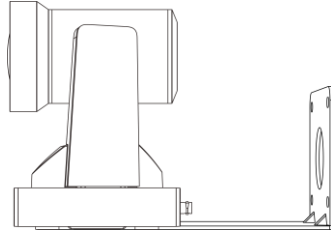

1. According to diameter and position of the 4 installation holes (As shown below) on the bracket, drill 4 holes on the wall and fix the bracket onto the wall by using 4 screws which should be prepared by you.

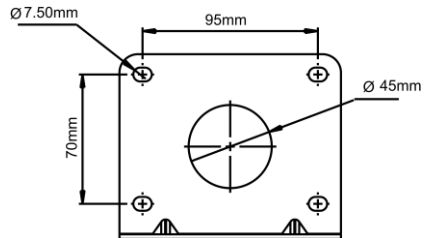

2. Before fixing the camera, set the DIP switches of the camera correctly.
3. Use inch screws to fix the camera on the bracket, fix the limit screw according to actual requirement, and make sure the camera is tightly fixed onto the bracket before your hands leave the camera.

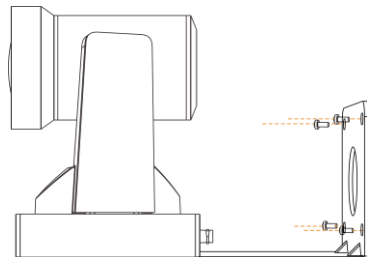

CONNECTIONS

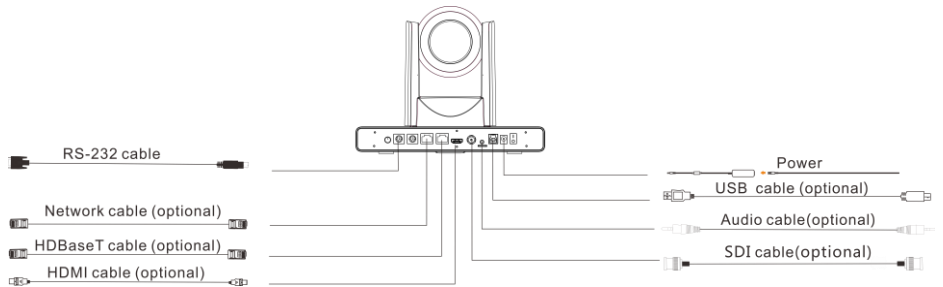

Note

If preset 0 has been saved, after power-on, camera moves to preset 0 automatically; if preset 0 has not been saved, after powered on, camera moves to Home position, where both pan and tilt angle is zero and zooming time is 1x.

MENU SETTINGS

Menu Configuration

Refer to Page 14	<VIDEO>	SHARPNESS	0, 1, 2, 3, 4, 5, 6, 7, 8, 9, 10, 11, 12, 13, 14, 15
		BRIGHTNESS	0, 1, 2, 3, 4, 5, 6, 7, 8, 9, 10, 11, 12, 13, 14
		CONTRAST	0, 1, 2, 3, 4, 5, 6, 7, 8, 9, 10, 11, 12, 13, 14
		GAMMA MODE	0, 1, 2, 3, 4
		2DNR LEVEL	1, 2, 3, 4, 5, OFF
		3DNR LEVEL	1, 2, 3, 4, 5, OFF
		WIDE DYNAMIC	1, 2, 3, 4, 5, OFF

<EXPOSURE>
Refer to Page
14

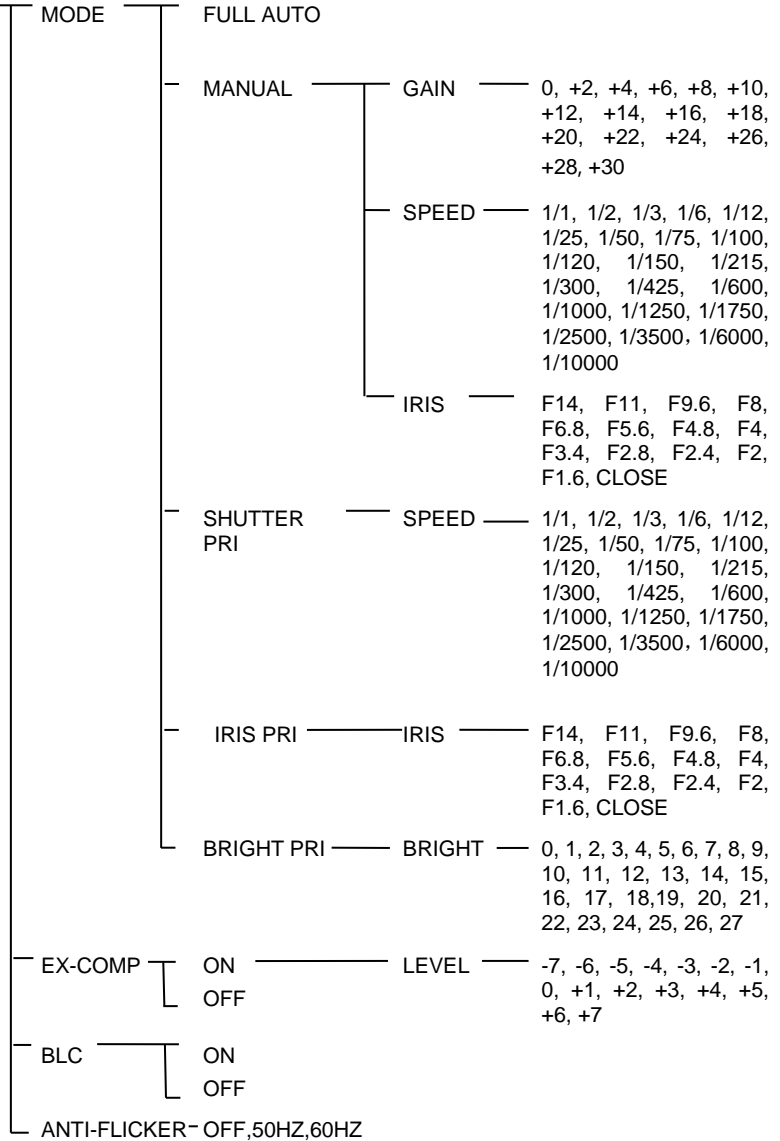

<COLOR> Refer to Page 15	WB MODE	—	AUTO, ATW, ONE PUSH, INDOOR, OUTDOOR, MANUAL, SODIUM LAMP, FLUO LAMP
	SATURATION	—	0, 1, 2, 3, 4, 5, 6, 7, 8, 9, 10, 11, 12, 13, 14
	HUE	—	0, 1, 2, 3, 4, 5, 6, 7, 8, 9, 10, 11, 12, 13, 14

<PAN TILT ZOOM> Refer to Page 16	PAN/TILT SPEED	—————	1, 2, 3, 4, 5, 6, 7, 8
	PTZ TRIG AF	—————	ON, OFF
	RATIO SPEED	—————	ON, OFF
	POWER UP ACTION	—————	PRESET 1, PRESET 2, PRESET 3, PRESET 4, PRESET 5, PRESET 6, PRESET 7, PRESET 8, PRESET 9, HOME

< SYSTEM > Refer to Page 16	ADDRESS	—————	1, 2, 3, 4, 5, 6, 7
	PROTOCOL	—————	VISCA, PELCO-P, PELCO-D
	BAUDRATE	—————	2400, 4800, 9600, 38400
	IR ADDRESS	—————	1, 2, 3, 4
	VIDEO FORMAT	—————	1080P60, 1080P50, 1080I60, 1080I50, 1080P30, 1080P25, 720P60, 720P50, 4KP30, 4KP25
	MOUNT MODE	—————	STAND, CEILING
	RS485 PORT	—————	HALF-DUPLEX-1, HALF-DUPLEX-2
	LANGUAGE	—————	ENGLISH

<STATUS> ——— ADDRESS ——— 1
Refer to Page ——— PROTOCOL ——— VISCA
17 ——— BAUD RATE ——— 9600
——— IR ADDRESS ——— 1
——— VIDEO FORMAT ——— 1080P25
——— MOUNT MODE ——— STAND
——— FIRMWARE VER ——— V1.0.0

<RESTORE DEFAULTS> Refer to Page17

Menu Explanation

Main Menu

Press **[MENU]** button to enter / exit menu.

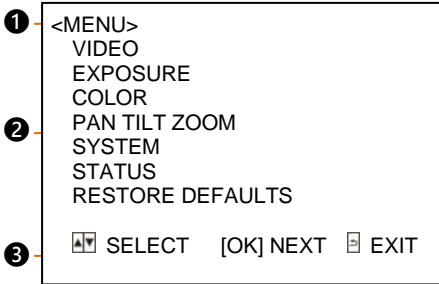

1 Menu Hint

It displays currently selected menu option.

2 Menu Options

It displays options under current menu hint.

Press **▲** or **▼** button to select among menu options, once font of options turned from white color to yellow color, it indicates the menu has been elected, press **OK** button to get into this menu.

3 Prompt Message

"**▲▼** SELECT" indicates it is possible to press **▲** or **▼** button to select menu options.

"**[OK]NEXT**" indicates it is possible to press **[OK]** button to enter next level menu.

"**[OK]EXIT**" indicates it is possible to press **[OK]** button to exit menu.

Submenus

From main menu, navigate to select

<EXPOSURE> menu, press **[OK]** to enter.

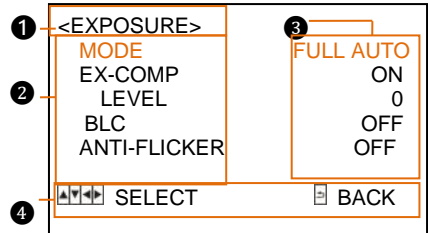

1 Menu Hint

It displays currently selected menu option.

2 Menu Options

It displays options under current menu hint.

Press **▲** or **▼** button to select among menu options, once font of options turned from white color to yellow color, it indicates the menu has been elected, press **[OK]** button to get into this menu.

3 Manual Exposure

Press **◀** or **▶** button to change value.

4 Prompt Message

"**▲▼** SELECT" indicates it is possible to press **▲** or **▼** to select menu options, press **◀** or **▶** to change value

"**▶** BACK" indicates it is possible to press **[▶]** to return to previous menu.

Video

VIDEO menu is used to change video value.

<VIDEO>	
SHARPNESS	8
BRIGHTNESS	7
CONTRAST	2
GAMMA MODE	0
2DNR LEVEL	OFF
3DNR LEVEL	OFF
WIDE DYNAMIC	OFF
SELECT	BACK

Available Options:

SHARPNESS: 0, 1, 2, 3, 4, 5, 6, 7, 8, 9, 10, 11, 12, 13, 14, 15.

BRIGHTNESS: 0, 1, 2, 3, 4, 5, 6, 7, 8, 9, 10, 11, 12, 13, 14.

CONTRAST: 0, 1, 2, 3, 4, 5, 6, 7, 8, 9, 10, 11, 12, 13, 14.

GAMMA MODE: 0, 1, 2, 3, 4.

2DNR LEVEL: 1, 2, 3, 4, 5, OFF.

3DNR LEVEL: 1, 2, 3, 4, 5, OFF.

WIDE DYNAMIC: 1, 2, 3, 4, 5, OFF.

Exposure

EXPOSURE menu is used to adjust exposure value.

<EXPOSURE>	
MODE	FULL AUTO
EXP-COMP	ON
LEVEL	0
BLC	ON
ANTI-FLICKER	OFF
SELECT	BACK

MODE:

FULL AUTO: Gain, Shutter Speed and Iris value are adjusted automatically accordingly to working environment.

MANUAL: manually adjust Gain, Shutter Speed and Iris.

GAIN: 0, +2, +4, +6, +8, +10, +12, +14, +16, +18, +20, +22, +24, +26, +28, +29, +30.

SPEED: 1/1, 1/2, 1/3, 1/6, 1/12, 1/25, 1/50, 1/75, 1/100, 1/120, 1/150, 1/215, 1/300, 1/425, 1/600, 1/1000, 1/1250, 1/1750, 1/2500, 1/3500, 1/6000, 1/10000s.

IRIS: F14, F11, F9.6, F8, F6.8, F5.6, F4.8, F4, F3.4, F2.8, F2.4, F2, F1.6, CLOSE.

SHUTTER PRI: Gain and Iris value are adjusted automatically according to working environment; shutter speed value is adjustable manually.

SPEED: 1/1, 1/2, 1/3, 1/6, 1/12, 1/25, 1/50, 1/75, 1/100, 1/120, 1/150, 1/215, 1/300,

1/425, 1/600, 1/1000, 1/1250, 1/1750,
1/2500, 1/3500, 1/6000, 1/10000s.

IRIS PRI: Gain and shutter speed value are adjusted automatically according to working environment; Iris value is adjustable manually.

IRIS: F14, F11, F9.6, F8, F6.8, F5.6, F4.8, F4, F3.4, F2.8, F2.4, F2, F1.6, CLOSE.

BRIGHT PRI: Manually adjust the video brightness.

BRIGHT: 0, 1, 2, 3, 4, 5, 6, 7, 8, 9, 10, 11, 12, 13, 14, 15, 16, 17, 18, 19, 20, 21, 22, 23, 24, 25, 26, 27.

EXP-COMP: Once EXP-COMP is set as On, below level options become available -7, -6, -5, -4, -3, -2, -1, 0, +1, +2, +3, +4, +5, +6, +7
+7 is the maximum compensation value for bright, -7 is the maximum compensation value for dark.



BLC: ON, OFF.

Backlight compensation (BLC) is video gain done automatically to correct the exposure of subjects that are in front of a bright light source.

ANTI-FLICKER (OFF, 50Hz, 60Hz): To avoid video flicker at power systems of different frequency.

Color

COLOR menu is used to adjust color related values. Available options:

< COLOR >	
WB MODE	MANUAL
R.GAIN	7
B.GAIN	7
SATURATION	7
HUE	7
  SELECT	 BACK

WB MODE: AUTO, ATW (auto tracking), ONE PUSH, INDOOR, OUTDOOR, MANUAL, SODIUM LAMP, FLUO LAMP.

“ONE PUSH”: In “ONE PUSH TRIGGER” mode, aim the camera at a pure white object (say a white paper), then press OK button.

“AUTO” mode: R.GAIN, G.GAIN and B.Gain can be chosen from -7~+7.

“MANUAL” mode: R.GAIN and B. GAIN value can be chosen from 0~255.

SATURATION: 0, 1, 2, 3, 4, 5, 6, 7, 8, 9, 10, 11, 12, 13, 14.

HUE: 0, 1, 2, 3, 4, 5, 6, 7, 8, 9, 10, 11, 12, 13, 14.

Pan/Tilt/Zoom

PAN/TILT/ZOOM is used to change pan/tilt/zoom value, available options:

<PAN TILT ZOOM>	
PAN/TILT SPEED	8
PTZ TRIG AF	ON
RATIO SPEED	ON
POWER UP ACTION	HOME
SELECT	BACK

PAN/TILT SPEED: 1, 2, 3, 4, 5, 6, 7, 8 the bigger the number is, the faster the speed is.

PTZ TRIG AF: Turn ON / OFF the auto focus when the camera pans / tilts / zooms.

RATIO SPEED (ON, OFF): Set the relation of PT speed as per zoom time. When it's on, PTZ speed will be faster when zoom time is bigger.

POWER UP ACTION: PRESET 1, PRESET 2, PRESET 3, PRESET 4, PRESET 5, PRESET 6, PRESET 7, PRESET 8, PRESET 9, HOME.

System

<SYSTEM>	
ADDRESS	1
PROTOCOL	VISCA
BAUD RATE	9600
IR ADDRESS	1
VIDEO FORMAT	1080P25
MOUNT MODE	STAND
RS485 PORT	HALF-DUPLEX-1
LANGUAGE	ENGLISH
SELECT	BACK

ADDRESS: 1, 2, 3, 4, 5, 6, 7.

PROTOCOL: VISCA, PELCO-D, PELCO-P.

BAUD RATE: 2400, 4800, 9600, 38400.

IR ADDRESS: 1,2,3,4, set camera address to be controlled by remote controller.

VIDEO FORMAT: 1080P60, 1080P50, 1080P30, 1080P25, 1080I50, 1920X1080I60, 1080I50, 720P60, 720P50.

MOUNT MODE: STAND, CEILING.

RS485 PORT:

HALF-DUPLEX-1: the camera will not return ACK/FINISH/FAULT msg.

HALF-DUPLEX-2: the camera will return ACK/FINISH/FAULT msg.

LANGUAGE: ENGLISH.

Status

```
< STATUS>
ADDRESS                1
PROTOCOL                VISCA
BAUD RATE              9600
IR ADDRESS              1
VIDEO FORMAT           1080P25
MOUNT MODE             STAND
FIRMWARE VER           V1.0.00
```

 BACK



Display information (address, protocol, baud rate, IR address, video format, mount mode, image version and firmware version) of the current camera.

Restore Defaults

```
< RESTORE DEFAULTS>
PRESS OK      CONFIRM
PRESS BACK   CANCEL
```

 BACK

RESTORE DEFAULTS option is used to reset all menus to default value.

Press  to confirm or press  to cancel and return to previous menu.

List Of Special Preset Commands

Preset No.	Function
93	Cruise, camera switches among saved 0~29 presets repeatedly and sequentially in fixed interval.
95	Get into menu
96	Delete all presets
99	Reboot the PTZ
100	Video format: 1920X1080P50
101	Video format: 1920X1080P25
102	Video format: 1920X1080I50
103	Video format: 1280X720P50
105	Video format: 1920X1080P60
106	Video format: 1920X1080P30
107	Video format: 1920X1080I60
108	Video format: 1280X720P60
122	Video format: 4KP30
123	Video format: 4KP25

iSmart CMS Application Software Guide

Network Connection

Connect the camera to network with an Ethernet cable, power on the camera.

LAN Connection

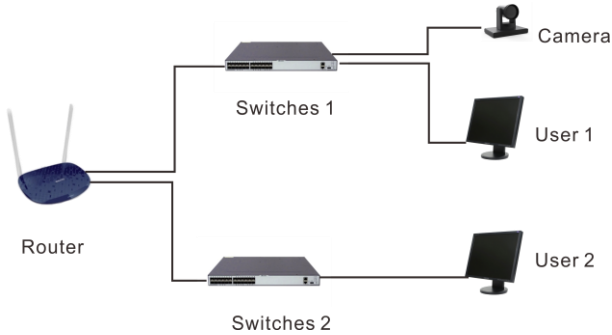

Please refer to the above diagram, user1 and user 2 are in the same router, they are considered as in the same LAN, connect the camera to the same LAN as where the PC is, and refer to below instructions as how to use the application software, then the camera can be found and connected from the online device list.

WAN Connection

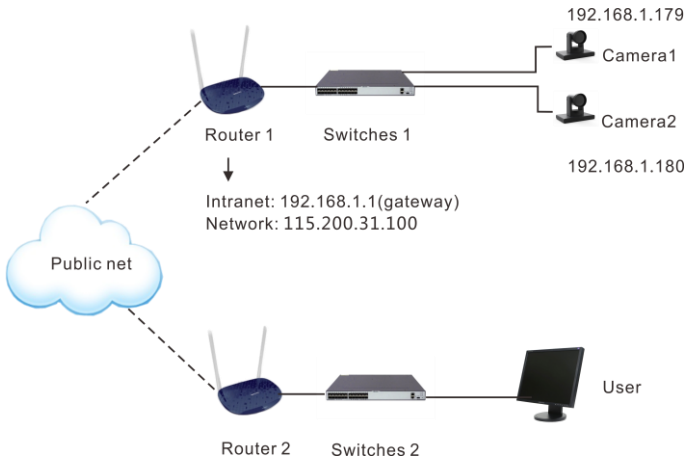

Please refer to the above diagram, user and the camera are in different routers, they are considered as in a WAN; in this condition, application software iSmartCMS can not search and find the camera automatically. User can still connect after below conditions are satisfied: (1) Set camera's IP address as static IP address (2) Router of the LAN where camera is connected supports Port Mapping. (3) Router of the LAN where camera is connected has fixed public IP address. Follow below steps to connect:

Step One

Set camera's IP address in LAN: connect user PC to the LAN (Router 1) where the camera is connected according to LAN connection instructions, use application software iSmartCMS to search and find the camera, then add it to manage; then set camera's IP address in the same network segment as the router 1. Camera's gateway is usually set at Router 1's LAN IP address, for example, 192.168.1.1, then camera's IP address can be set as for example 192.168.1.179 or 192.168.1.180 as long as they are in the same network segment.

Steps Two

Route Mapping: user PC logs into router configuration menu, gets into "Port Mapping" (router management authorization may be required); refer to below picture, DO NOT tick "Do not apply this rule", from first frame under "External port", input any number from 1~65535, but preferred to be set at more than 10000 like 10200 so there will be less port conflict possibility. From "Internal IP", input the camera1's IP address 192.168.1.179, from first frame of "Internal Port", input 3478, (all cameras use this same port number). "Protocol" and "Mapping Line" can be default, from "Note", input "Camera 1's mapping port" or something to understand.

Port mapping

List of rules

<input type="checkbox"/> Do not apply this rule	If you disable this rule, the following configuration will only be saved but will not be applied.
Not applied	
External port	<input type="text"/> <input type="text"/> You can input an external port or an external port segment to be mapped to an open port or port segment of an internal host. If you leave it blank, the external port or port segment is identical to the internal port or port segment. The range is between 1 and 65535.
Internal IP	<input type="text"/> The IP address of the internal host that provides external service. For example: <i>192.168.0.50</i>
Internal port	<input type="text"/> <input type="text"/> The open port or port segment of the internal host that provides external services. The range is between 1 and 65535.
Protocol	<input type="text" value="TCP"/> <input type="text"/> The protocol used for port mapping can be TCP, UDP or both.
Mapping line	<input type="text" value="Any"/> <input type="text"/> The line used for port mapping can be single WAN or multi WAN.
Note	<input type="text"/> You can write a short note to describe this mapping rule. For example: <i>The WEB server for Marketing Department.</i>

Save

Back

Help

Port mapping function can map the service port of the intranet server host to extranet, so external network users can access the services offered by the intranet server through the external IP address and port of the router.

Notice:

· Port mapping works only if "Block extranet requests" on the Attack defense page is disabled.

Step Three

Access from external network: router 1's public IP address is 115.200.31.100, for example, go through the above steps one and two, WAN users under router 2 can access camera 1 through IP address 115.200.31.100 + port 10200. Then, in WAN, the mapping of camera 1 and (IP 115.200.31.100 + port 10200) is established. Camera 2 can use another external port such as 10320, so mapping of camera 2 with (IP 115.200.31.100 + port 10320) is established. In the "Managed Device" of the client software iSmart CMS, click "+ Add", enter the IP address 115.200.31.100 and port 10200 and other information, then the camera 1 can be accessed and controlled.

Client Software Instruction

Search And List The Camera

Install and open the client software in PC, enter the main interface:

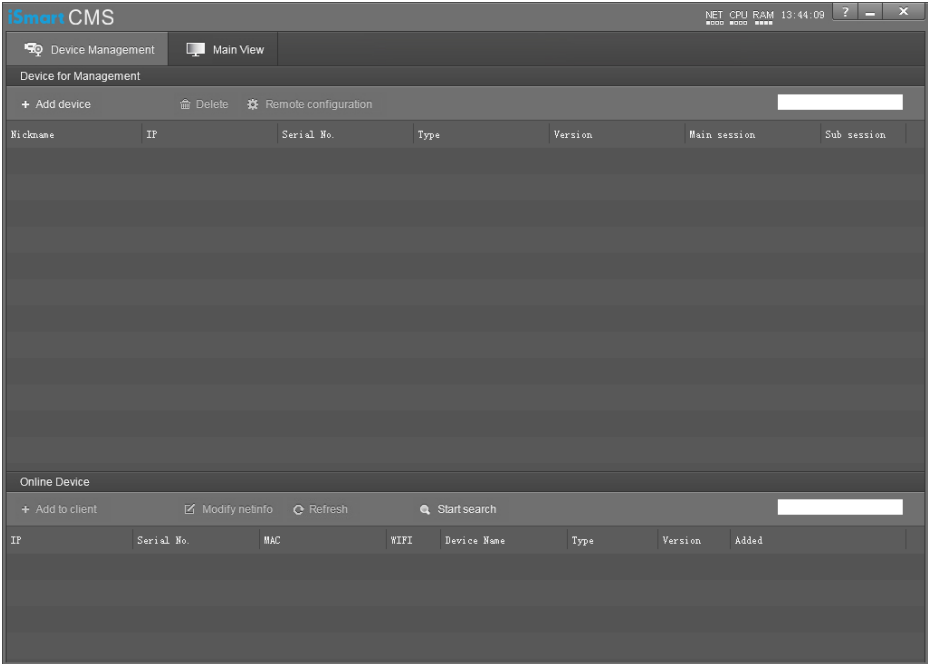

If the camera and PC are in the same LAN, click “Start Search”, then searching starts and all online devices will be listed, as the picture shown below:

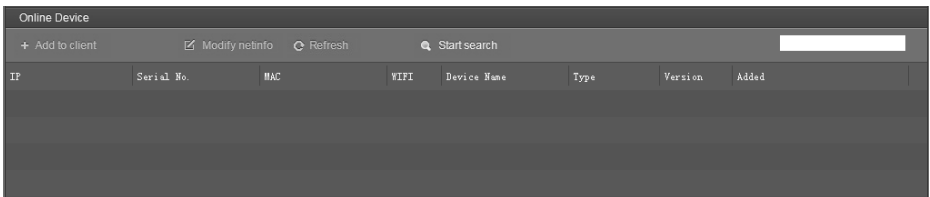

To modify the device IP address, input the IP address, mask, gateway in the “Modify Network” column.

X

Modify Network Parameter

Ethernet

Device information:

CameraName:

Mac:

SN:

Network information:

ConnType:

IP:

Mask:

Gateway:

DNS1:

DNS2:

Modify

To control and preview a camera, first choose the device, modify its IP address as the IP address of the same LAN, then click "Add to Client" as the picture shown below.

Online Device							
+ Add to client							
<input checked="" type="checkbox"/> Modify netinfo <input type="checkbox"/> Refresh <input type="text" value="Stop search"/>							
IP	Serial No.	MAC	WiFi	Device Name	Type	Version	Added
10.0.3.128	L6D3V3H2B9OUQUK4G224	00:04:05:01:88:89	No	av200_4K	L2CS-FT9H	1.0.00	
10.0.3.212	828663H2BYOUQU4515X2	00:04:05:01:88:7E	No	4200t-rdtst	E200T	2.0.00	
10.0.3.240	S00795K2B10SQW241W0	00:04:05:01:88:36	No	S00795K2B10SQW241W0	LTC	5.0.04	

Please check that all IP addresses are in the same LAN.

Remote Configuration

Choose the camera in the device list, click "Remote Configuration" in the column to upgrade or config the camera.

Streaming

Remote Configuration ✕

Streaming Network Rtmp Protocol UP.PM Upgrade UN/PW

Stream type	Main stream	Channels	MONO
Resolution	1080P	Encode type	AAC
Video rate type	CBR	Sample rate	16KHz
Max rate (Kbps)	10000	Audio rate	48Kbps
Frame rate	25	Input pin	LineIn
Key frame interval	25	Volume	<input type="range" value="50"/>
Video coding type	H264		<input type="button" value="Save"/>
Encode Level	Base		

- Stream type: set the parameters of main stream, sub stream, third stream, fourth stream.
- Resolution: set among 4K (3840*2160), 1080P (1920*1080), 720P (1280*720), D1&QVGA (320*240), choose resolutions based on actual requirements and capability of device. The higher the resolution is, the better network requirements will be needed.
- Video rate type: choose from CBR, VBR.
- Max rate: configure max stream rate or adjustable stream rate.
- Frame rate: choose from different frame per second.
- Key frame interval: configure the number of frames between the two key frames. The larger the key frame interval is, the smaller the fluctuation of the byte will be, but the image quality is relatively poor. Vice versa, the larger the fluctuation of the byte will be, the higher the image quality will be.
- Video coding type: choose H.264 or H.265.
- Encode level: choose from Base, Main and High.

Network

The screenshot shows a 'Remote Configuration' dialog box with a 'Network' tab selected. The dialog has a title bar with a close button (X) and a tabbed interface with the following tabs: Streaming, Network, Rtmp, Protocol, UP.PM, Upgrade, and UN/PW. The 'Network' tab contains the following fields:

Field	Value	Field	Value
Connect with	Static IP	rtsp port	5000
IP Address	10.0.3.194	app port	5002
Mask	255.255.255.0		
Gateway	10.0.3.1		
DNS 1	0.0.0.0		
DNS 2	0.0.0.0		

A 'Save' button is located at the bottom right of the dialog box.

- Connect with: please choose from Static IP or dynamic IP address.
- IP address: input IP address for the camera.
- Mask: input mask address for the camera.
- Gateway: input gateway IP address.
- DNS 1: server-prior, input DNS address for the device.
- DNS 2: it will be used in case DNS1 server is not working.
- Port: streaming port (RTSP) and application port (SDK connection) can be configured. The range of stream ports is 3479~7999 and 554, default is 554. The range of application ports is 3479~7999, default is 5002.
- Click the "Save" button after setting is completed.
- Camera will connect to ethernet after above-mentioned operations.

RTMP

Remote Configuration ✕

Streaming Network Rtmp Protocol UP.PM Upgrade UN/PW

RTMP 1

Main stre:

RTMP 2

Sub strear

In RTMP1 and RTMP2, main stream, sub stream, third stream, fourth stream can be chosen to stream.

Protocol

The image shows a 'Remote Configuration' dialog box with a close button (X) in the top right corner. The dialog has a tabbed interface with the following tabs: Streaming, Network, Rtmp, Protocol, UP,PM, Upgrade, and UN/PW. The 'Protocol' tab is currently selected. The configuration fields are as follows:

Enable	<input type="text" value="Enable"/>
Protocol	<input type="text" value="UDP"/>
Camera as	<input type="text" value="Server"/>
IP	<input type="text" value="0.0.0.0"/>
Port	<input type="text" value="1259"/>

At the bottom of the dialog is a 'Save' button.

- Enable / Disable: enable / disable transparent transmission.
- Protocol: choose TCP or UDP protocols.
- Camera as: choose Client or Server.
- IP: when the camera is set as a client, the IP address of the transmitted camera is needed. When the camera is set as a server, the IP address can be left as black.
- Port: choose from 1-65535 as transparent transmission port.

Upgrade

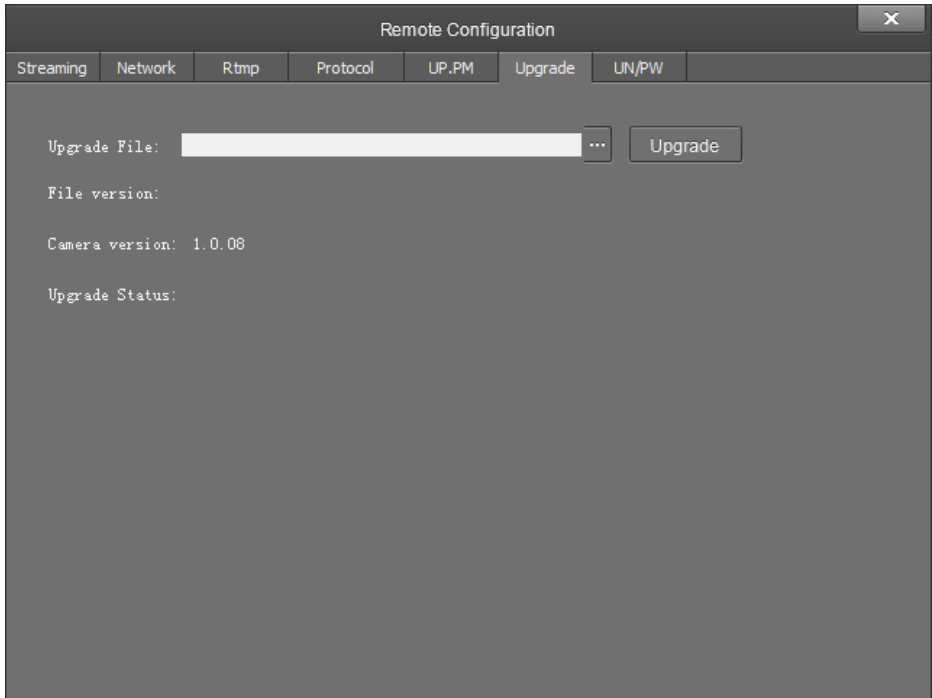

Click "Upgrade" menu to enter the main interface, as the picture shown above.

Click to search and load the updating firmware, then click "Upgrade" to start upgrading. Do not power off the camera during upgrading. After upgrading is completed, camera will reboot.

UN/PW

- Password setting: when a password is required, the camera can be accessed only after a correct password is input.
- Reboot: reboot the camera.

The screenshot shows a 'Remote Configuration' window with a tabbed interface. The 'UN/PW' tab is selected. The window contains the following fields and controls:

- Streaming** | **Network** | **Rtmp** | **Protocol** | **UP.PM** | **Upgrade** | **UN/PW** | [Close]
- Old password: [Text Field]
- New password: [Text Field]
- Confirm: [Text Field]
- [Save]
- Camera name: **AMC-H**
- [Save]
- Local Time: 2019-07-30 09:49:46 [OK]
- Display Time
- Time Format: YYYY-MM-DD HH:mm:ss [OK]
- Enable NTP
- TimeZone: +00:00
- NTP Server: [Text Field] [OK]
- Reboot: [Reboot] [Reset]

Preview

Click “Main View” to get into camera control and preview part as below.

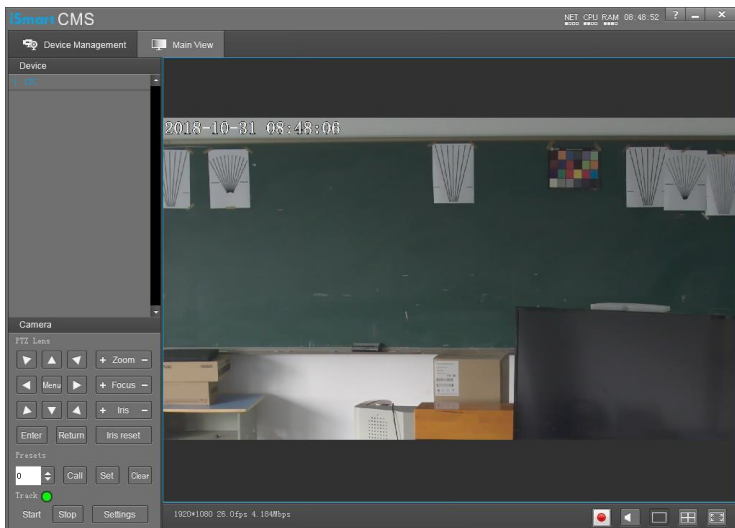
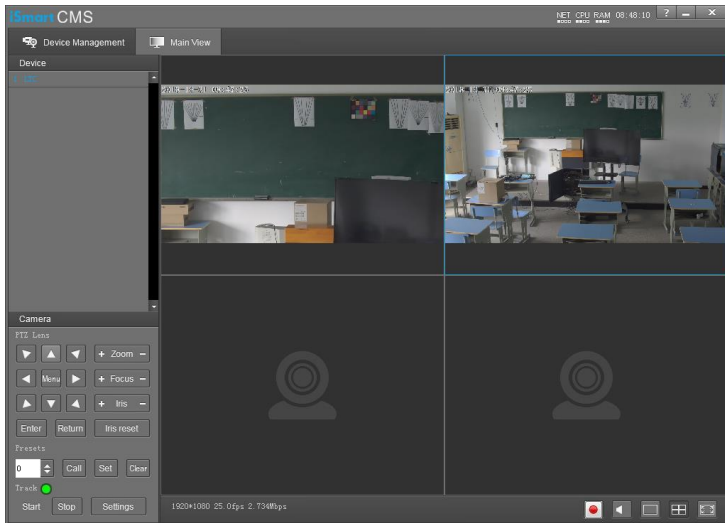

This interface includes three main parts: device list, device control, video preview

- Device: it displays all online cameras added to “Device Management”.

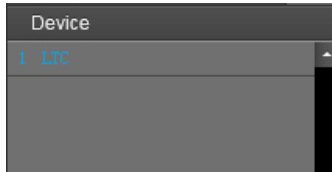

- Device Control: get control of the selected camera (camera name in blue).

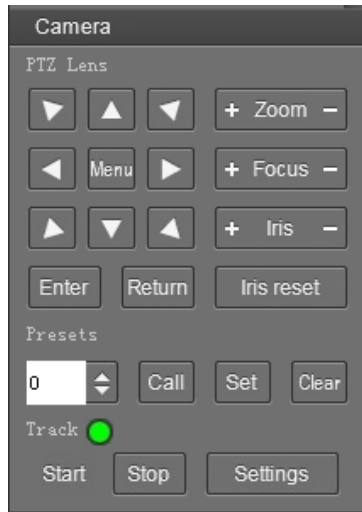

- Video Preview: double click the camera in the list, main camera stream will be displayed in the preview window; or right click the selected camera from the left column to get its main or substream video. Video preview mode can be single video or four videos, when in four videos mode, select one of the four video's then choose the bottom right icon to enlarge this selected video to a big single window.

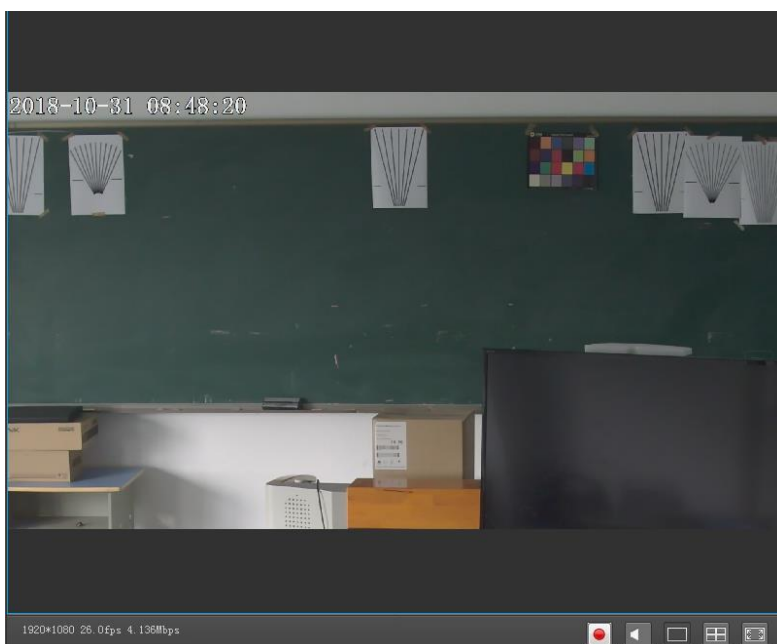
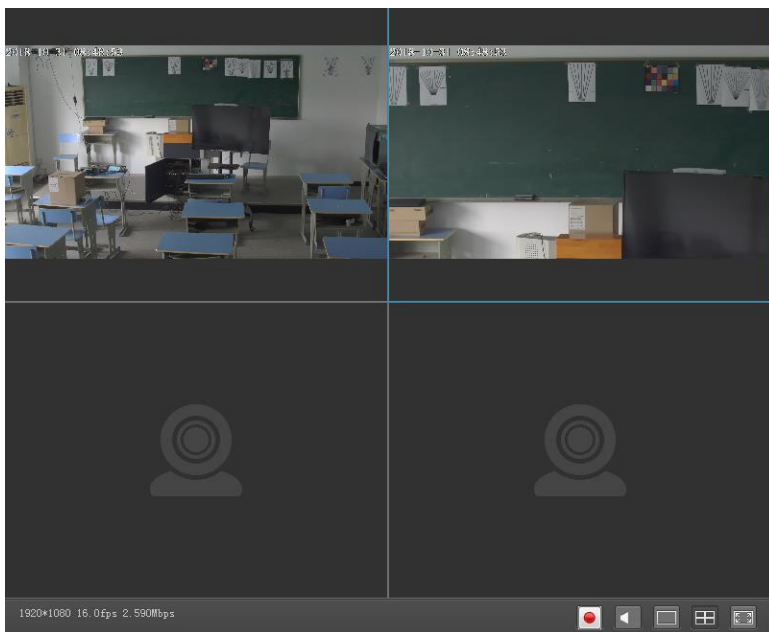

ANNEX 1 TECHNICAL SPECIFICATIONS

Camera	
Image Sensor	1/1.8" CMOS, 8.41 megapixel
Focal Lens	f=4.2~50.4mm
Iris	F1.8 – F2.8
Optical Zoom	12x
Horizontal Viewing Angle	82.6° -8°
Focus System	Auto, Manual, PTZ Trigger, One Push Trigger
Exposure Control	Auto, Manual, Shutter Priority, Iris Priority, Smart
Min. Illumination	0.5lux(color), 0.1lux(B/W)
Shutter Speed	1/1 to 1/10,000s
Gain	Auto /Manual
White Balance	Auto, Indoor, Outdoor, One Push, Manual, Auto Tracking, Sodium Lamp, Fluo Lamp
Wide Dynamic	Yes
Back Light Compensation	Yes
Digital Noise Reduction	2D/3D
S/N	≥50dB
Function	
Pan Angle	-170°~+170°
Tilt Angle	-30°~+90°
Pan Speed	0.1°~120°/S
Tilt Speed	0.1°~80°/S
Preset Number	256
OSD	Yes
Image Flip	Yes
Video Output	
Video Format	4KP30, 1080P60, 1080I60, 1080P30, 720P60 4KP25, 1080P50, 1080I50, 1080P25, 720P50
Network	
Resolution	Max. support 3840x2160@30fps
Image Compression	H.265, H.264
Audio Compression	AAC
Protocols	ONVIF, RTSP, RTMP, ONVIF, TCP, UDP
Dual Stream	Support
Interface	
Video Output	1 channel 3G-SDI, Max. support 1080P60 output 1 channel HDMI, Max. support 4KP30 output 1 channel HDBaseT (optional), Max. support 4KP30 output
Audio	1 channel LINE IN, 1 channel LINE OUT
Network Interface	RJ45 (10M/100M) interface, Optional POE
USB Interface	1 channel USB 3.0 (reserved)

Local Storage	TF card, Max. 64G
Control Interface	1 channel RS-485, 1 channel RS-232 IN, 1 channel RS-323 OUT
IR Throughout Output	1 channel IR throughout output
General	
Protocols	VISCA (support daisy chain) / PELCO-P / PELCO-D
Power	DC12V
Power Consumption	<20W
Operating Temperature	0°C~+40°C
Storage Temperature	-20°C~+60°C
Dimensions (WxHxD)	251mmx145mmx194mm
Weight	2.2KG
Color	Grey

ANNEX 2 SIZE AND DIMENSION

Front

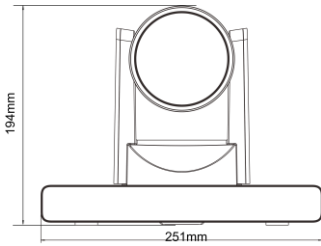

Top

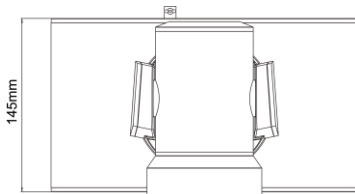

Rear

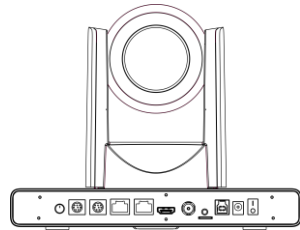

Side

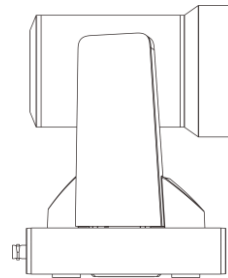

Bottom

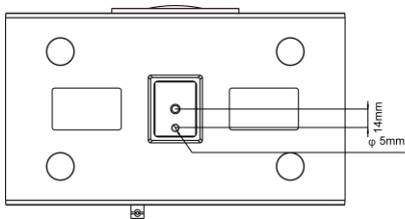

ANNEX 3 SW1 DEFINITION

DIP No. Address	1	2	3	4	5	6
0	OFF	OFF	OFF	OFF	OFF	OFF
1	ON	OFF	OFF	OFF	OFF	OFF
2	OFF	ON	OFF	OFF	OFF	OFF
3	ON	ON	OFF	OFF	OFF	OFF
4	OFF	OFF	ON	OFF	OFF	OFF
5	ON	OFF	ON	OFF	OFF	OFF
6	OFF	ON	ON	OFF	OFF	OFF
7	ON	ON	ON	OFF	OFF	OFF
8	OFF	OFF	OFF	ON	OFF	OFF
9	ON	OFF	OFF	ON	OFF	OFF
10	OFF	ON	OFF	ON	OFF	OFF
11	ON	ON	OFF	ON	OFF	OFF
12	OFF	OFF	ON	ON	OFF	OFF
13	ON	OFF	ON	ON	OFF	OFF
14	OFF	ON	ON	ON	OFF	OFF
15	ON	ON	ON	ON	OFF	OFF
16	OFF	OFF	OFF	OFF	ON	OFF
17	ON	OFF	OFF	OFF	ON	OFF
18	OFF	ON	OFF	OFF	ON	OFF
19	ON	ON	OFF	OFF	ON	OFF
20	OFF	OFF	ON	OFF	ON	OFF
21	ON	OFF	ON	OFF	ON	OFF
22	OFF	ON	ON	OFF	ON	OFF
23	ON	ON	ON	OFF	ON	OFF
24	OFF	OFF	OFF	ON	ON	OFF
25	ON	OFF	OFF	ON	ON	OFF
26	OFF	ON	OFF	ON	ON	OFF
27	ON	ON	OFF	ON	ON	OFF
28	OFF	OFF	ON	ON	ON	OFF
29	ON	OFF	ON	ON	ON	OFF
30	OFF	ON	ON	ON	ON	OFF
31	ON	ON	ON	ON	ON	OFF
32	OFF	OFF	OFF	OFF	OFF	ON
33	ON	OFF	OFF	OFF	OFF	ON
34	OFF	ON	OFF	OFF	OFF	ON
35	ON	ON	OFF	OFF	OFF	ON
36	OFF	OFF	ON	OFF	OFF	ON
37	ON	OFF	ON	OFF	OFF	ON
38	OFF	ON	ON	OFF	OFF	ON
39	ON	ON	ON	OFF	OFF	ON

40	OFF	OFF	OFF	ON	OFF	ON
41	ON	OFF	OFF	ON	OFF	ON
42	OFF	ON	OFF	ON	OFF	ON
43	ON	ON	OFF	ON	OFF	ON
44	OFF	OFF	ON	ON	OFF	ON
45	ON	OFF	ON	ON	OFF	ON
46	OFF	ON	ON	ON	OFF	ON
47	ON	ON	ON	ON	OFF	ON
48	OFF	OFF	OFF	OFF	ON	ON
49	ON	OFF	OFF	OFF	ON	ON
50	OFF	ON	OFF	OFF	ON	ON
51	ON	ON	OFF	OFF	ON	ON
52	OFF	OFF	ON	OFF	ON	ON
53	ON	OFF	ON	OFF	ON	ON
54	OFF	ON	ON	OFF	ON	ON
55	ON	ON	ON	OFF	ON	ON
56	OFF	OFF	OFF	ON	ON	ON
57	ON	OFF	OFF	ON	ON	ON
58	OFF	ON	OFF	ON	ON	ON
59	ON	ON	OFF	ON	ON	ON
60	OFF	OFF	ON	ON	ON	ON
61	ON	OFF	ON	ON	ON	ON
62	OFF	ON	ON	ON	ON	ON
63	ON	ON	ON	ON	ON	ON

DIP No.	7	
Reserved	Reserved	Reserved
DIP No.	8	
Mounting Type	ON	Ceiling
	OFF	Stand

TROUBLESHOOTING

Problem	Possible Cause	Solution
No action or image after power-on	Power supply failure	Check power supply
	Power adapter damaged	Replace power adapter
	Power cable connection got loosen	Check & reconnect
No self-testing after power-on, or with motor noise	Power cable is too long	Use a shorter cable
	Power adapter damaged	Replace power adapter
	Mechanical failure	Repair
Not controllable from remote controller	Low battery of remote controller	Change battery for remote controller
	Exceed remote control distance	Control within distance of 8M
After power-on, self-test successfully, but not controllable	Wrong address / protocol / baud rate	Check & set again
	Wrong connection or open circuit of RS-232 cable	Check & reconnect
Video loss when pans / tilts / zooms	Power cable is too long	Use a shorter cable
	Power adapter damaged	Replace power adapter
	Video cable not properly connected	Replace with a good video cable
Video captured after connected to digital video interface of a capture device is not good as the video captured after connected directly analog video interface of the capture device	Different video capture devices have different video capturing performance, image quality maybe worse after it has been converted from analog to digital	Consult video capture device supplier for more information

The user manual is only for a reference, if there are any changes or differences, please ask for the latest version from your supplier

CA/YF-AMCH-ZD-015

Y06020710002